

Automatic-Center-Point

> ACP-TURNADO <

Safety instructions

This safety instruction/declaration has to be kept on file for the whole lifetime of the product.

TRANSLATION OF THE ORIGINAL SAFETY INSTRUCTION



ACP M12-M30 /
ACP 1/2"-1 1/4"



ACP M36-M42 /
ACP 1 1/2"-1 3/4"



RUD Ketten
Rieger & Dietz GmbH u. Co. KG
73428 Aalen
Tel. +49 7361 504-1370
Fax +49 7361 504-1460
sling@rud.com
www.rud.com

RUD-Art.-Nr.: 7911875-EN / 05.021

Automatic Center Point - for bolting

ACP



EG-Konformitätserklärung

entsprechend der EG-Maschinenrichtlinie 2006/42/EG, Anhang II A und ihren Änderungen

Hersteller: **RUD Ketten**
Rieger & Dietz GmbH u. Co. KG
Friedensinsel
73432 Aalen

Hiermit erklären wir, dass die nachfolgend bezeichnete Maschine aufgrund ihrer Konzipierung und Bauart, sowie in der von uns in Verkehr gebrachten Ausführung, den grundlegenden Sicherheits- und Gesundheitsanforderungen der EG-Maschinenrichtlinie 2006/42/EG sowie den unten aufgeführten harmonisierten und nationalen Normen sowie technischen Spezifikationen entspricht.
Bei einer nicht mit uns abgestimmten Änderung der Maschine verliert diese Erklärung ihre Gültigkeit.

Produktbezeichnung: Automatic Center Point
ACP - TURNADO

Folgende harmonisierten Normen wurden angewandt:
DIN EN 1677-1 : 2009-03 DIN EN ISO 12100 : 2011-03

Folgende nationalen Normen und technische Spezifikationen wurden außerdem angewandt:
ASME B30.26 : 2015 BGR 500, KAP2.8 : 2008-04

Für die Zusammenstellung der Konformitätsdokumentation bevollmächtigte Person:
Michael Betzler, RUD Ketten, 73432 Aalen

Aalen, den 12.02.2019

Hermann Kolb, Bereichsleitung MA

Name, Funktion und Unterschrift Verantwortlicher



EC-Declaration of conformity

According to the EC-Machinery Directive 2006/42/EC, annex II A and amendments

Manufacturer: **RUD Ketten**
Rieger & Dietz GmbH u. Co. KG
Friedensinsel
73432 Aalen

We hereby declare that the equipment sold by us because of its design and construction, as mentioned below, corresponds to the appropriate, basic requirements of safety and health of the corresponding EC-Machinery Directive 2006/42/EC as well as to the below mentioned harmonized and national norms as well as technical specifications.
In case of any modification of the equipment, not being agreed upon with us, this declaration becomes invalid.

Product name: Automatic Center Point
ACP - TURNADO

The following harmonized norms were applied:
DIN EN 1677-1 : 2009-03 DIN EN ISO 12100 : 2011-03

The following national norms and technical specifications were applied:
ASME B30.26 : 2015 BGR 500, KAP2.8 : 2008-04

Authorized person for the configuration of the declaration documents:
Michael Betzler, RUD Ketten, 73432 Aalen

Aalen, den 12.02.2019

Hermann Kolb, Bereichsleitung MA

Name, function and signature of the responsible person

INHALT

1	Safety instructions	2
2	Intended use	2
3	Instructions for assembly and use	2
3.1	General information	2
3.2	Hints for mounting	3
3.3	Hints for the usage	4
3.3.1	General information regarding use	4
3.3.2	General information regarding the spring ...	5
3.3.3	Permitted lifting and turning actions	5
3.3.4	Prohibited lifting and turning actions	6
3.4	Disassembly / assembly of the RUD bolt	6
3.4.1	Disassembly of the bolt	6
3.4.2	Assembly of the bolt	6
4	Inspection / Repair / Disposal	6
4.1	Hints for the regularly inspection	6
4.2	Inspection criteria for the regularly examination carried out by the operator:	7
4.3	Additional inspection criteria for the competent person resp. auditor	7
4.4	Disposal	7
5	Tables/Overview	8



Carefully read the instructions prior to using Automatic Center Point bolttable lifting points (hereinafter referred to as ACP). Make sure you have understood everything.

Failure to observe the instructions can result in physical injury or material damage and means that the warranty no longer applies.

ENGLISH

1 Safety instructions



WARNING

Wrong assembled or damaged ACP as well as improper use can lead to injuries of persons and damage of objects when load drops.

Please inspect all ACP before each use.

- Keep all body parts like fingers, hands, arms, etc. out of the hazardous area during the lifting operation.
- Attention: When suspension ring pivots there is a risk of pinching.
- All ACP lifting points must only be used by authorized and trained persons in adherence with DGUV Regulations 109-017 and according to the country-specific provisions and regulations outside Germany.
- The stated WLL at the ACP must not be exceeded.
- The ACP must be able to rotate by 360° once it is tightened.
- The ACP is not permissible to be rotated permanently under load.
- Any technical modifications at the ACP are prohibited.
- Keep persons out of the hazardous area.
- Detention under a floating load is forbidden.
- Jerkily lifts with shock loads must be avoided.

- When the lift starts, pay attention to a stable position of the load. Avoid swinging of the load.
- Damaged or worn ACPs must no longer be used.

2 Intended use

ACP must only be used for the assembly at loads or in combination with lifting means.

They are intended to hinge lifting means.

ACP's may also be used as lashing points to hinge lashing means.

ACP's may only be used for the purposes described here.

3 Instructions for assembly and use

3.1 General information

- Suitability for use at certain temperatures:
Reduce the bolts' load bearing capacities as follows according to the bolts' class of strength in conjunction with ACPs as a result of the applied bolts:
-40°C to 100°C → no reduction
100°C to 200°C minus 15 % (212 to 392°F)
200°C to 250°C minus 20 % (392 to 482°F)
250°C to 350°C minus 25 % (482 to 662°F)
Temperatures over 350°C (662°F) are not permitted!

Note the maximum application temperature of the enclosed nuts (optional).

- Clamping nuts as per DIN EN ISO 7042 (DIN 980) can be used up to at max. 150°C.
- Collar nuts as per DIN 6331 can be used up to at max. +300°C. Note additional reduction factors.
- ACPs must not be brought into contact with aggressive chemicals, acids or their vapours.
- Mark the attachment positions of the ACPs with a contrasting colour for easy identification.
- RUD supplies ACPs including a crack-tested hex bolt (length up to L_{max} , see Table 2).
M12-M24 or 1/2"-1": ICE-BOLT
M30-M42 or 1 1/4"-1 3/4": 10.9 bolt

ATTENTION

Use the corresponding size for the listed class of strength only! Exclusively use genuine RUD-ICE-BOLTS for M12-M24 or 1/2"-1" sizes.

- Genuine bolts (ICE-BOLT and 10.9 bolts) are available from RUD as spare parts.
- If 10.9 bolts from the aftermarket are used instead of an original RUD bolt, especially at the dimension M30-M42 or 1 1/4"-1 3/4", make sure that they have been 100 % crack detected. A written confirmation from the supplier must be added to the ACP documents.

The average notch bar impact test at the lowest permitted usage temperature must be at minimum 36 J. This specification is required as per the test criteria for lifting points GS OA 15-04.



NOTE

Disassembly/assembly to check or replace the bolt must only be carried out by an authorized person (see section 3.4 Disassembly / assembly of the RUD bolt).

Variants

- Metric Vario lengths are supplied by RUD with a washer and a crack-tested nut as per DIN EN ISO 7042 or with a crack-tested collar nut as per DIN 6331.
- If the ACP is exclusively used for lashing, the load-bearing capacity value can be doubled:
LC = Permitted lashing force = 2 x load-bearing capacity (WLL)



NOTE

If the ACP is/was used as a lashing point, with a force higher than the WLL, it must not be used as a lifting point afterwards. If the ACP is/was used as a lashing point, up to the WLL only, it can still be used afterwards as a lifting point.

- The marking of the technical details are shown as follows:
 - **M12-M30 or 1/2"-1 1/4"**: The markings are shown on top of the bushing and on the head of the bolt (see Pic. 1).
 - **M36-M42 or 1 1/2"-1 3/4"**: The markings are shown on the deflector disc and the head of the bolt (see Pic. 2).

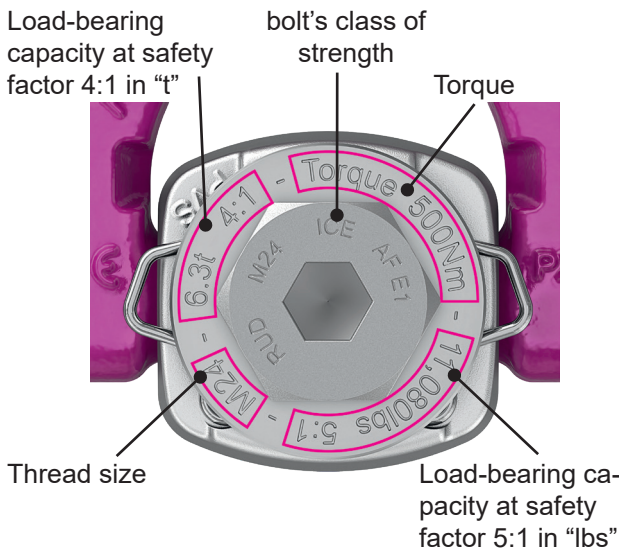

Pic. 1: ACP M12-M30 or 1/2"-1 1/4" - Identification of bush/bolt

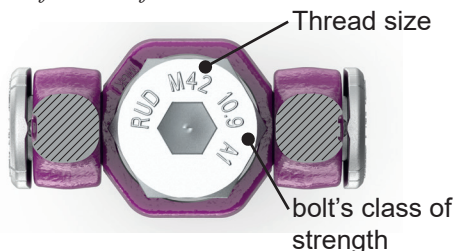

Pic. 2: ACP M36-M42 or 1 1/2"-1 3/4" - Identification of bolt

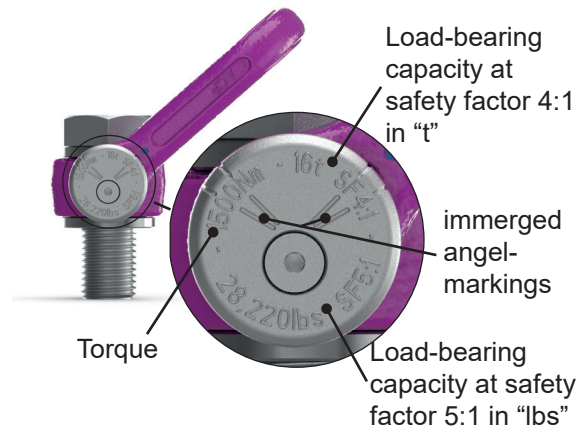

Pic. 3: ACP M36-M42 or 1 1/2"-1 3/4" - Identification of deflector disc



HINT

Angel marking helps to estimate 45°- or 60°-position of suspension ring.

3.2 Hints for mounting

The following applies in general:

- The installation area must be selected carefully to ensure that the transferred forces can be absorbed by the base material without any deformation. The professional organisation recommends the following minimum thread engagement length:
 - 1 x M in steel (minimum quality S235JR [1.0037])
 - 1.25x M in cast part (e.g. GG 25)
 - 2 x M in aluminium alloys
 - 2.5 x M in light alloys with low strength (M = thread size, e.g. M 20)
- In the case of light metals, non-ferrous metals and grey cast iron, the allocation of the threads must be selected such that the load-bearing capacity of the thread corresponds to the requirements of the base material in question.
- Define installation location of the ACP in such a way that inadmissible stresses caused by twisting or flipping of the load will be avoided:
 - **Single strand lifting:**
Position suspension ring vertically above load's centre of gravity
 - **Double strand lifting:**
Position lifting means on each side and above load's centre of gravity
 - **Three and four strand lifting:**
Position lifting means evenly in one level around load's centre of gravity.
- Symmetry of the load:
Determine the required load-bearing capacity of the individual lifting point for both symmetrical and asymmetrical loading according to the physical relationship described by the following formula:

$$W_{LL} = \frac{G}{n \times \cos \beta}$$

W_{LL} = Required load-bearing capacity of the lifting point/single strand (kg)
 G = Load weight (kg)
 n = Number of load-bearing strands
 β = Angle of inclination of the individual strand

The number of load-bearing strands is:

	Symmetry	Asymmetry
Two-strand	2	1
Three/four-strand	3	1

Table 1: Load-bearing strands (see Table 3)



NOTE

At unsymmetrical loads, the WLL of a single lifting point must at least correlate with the load weight.

- A plane bolt on surface ($\varnothing E$, Table 2) with rectangular machined thread holes must be assured. The execution of the threaded hole must be machined acc. to DIN 76 (chamfer at the max. $1.05 \times d$). The tapped holes must be at least deep enough that the bearing surface of the lifting point sits properly at the surface of the load. Through holes must be machined acc. to DIN EN 20273-middle.
- The ACP must be able to rotate by 360° when installed and tightened. Observe the following hints:
 - For a single lift it is sufficient to manually tighten the bolts until they are in contact with the ACP contact surface on the bolt surface using a spanner.

Attention: Do not exceed the specified tightening torque

- If the lifting point will be **permanently installed**, the stated torque (+/- 10 %) must be applied with the values acc. to Table 2.
- When turning loads using the ACP (see section 3.3.3 Permitted lifting and turning actions) it is necessary to tighten the bolt with a torque (+/- 10 %) acc. to Table 2.
- When shocks or vibrating loads occur, especially at through hole bolt constructions in combination with a nut, unintentional opening of the bolt connection may occur.

Securing options: Observing the required torque. Use of a liquid bolt securing glue, f.e. Loctite (Adapted to the usage, observe user instruction of manufacturer).

- Finally check correct installation (see section 4 Inspection / Repair / Disposal).

3.3 Hints for the usage

3.3.1 General information regarding use

- The whole lifting point must be inspected regularly by a competent person in regard of proper installation, tightening of bolt, strong corrosion, cracks at load bearing parts and deformations (e.g. by the person responsible for attachment). See section 4 Inspection / Repair / Disposal.



WARNING

Wrong assembled or damaged ACPs as well as inappropriate usage may lead to injury of persons and property damage when load drops.

Please inspect all ACP before each use.

- RUD components have been designed as per DIN EN 818 and DIN EN 1677 for a dynamic load of 20,000 load cycles.
 - Observe and be aware that multiple load cycles can occur during a lifting operation.
 - Observe the risk of product damage caused by high dynamical influences at high load cycle numbers.
 - BG/DGUV Germany's employer insurance association recommends: At high dynamical loading with a high number of load cycles (permanent use), the stress at WLL acc. to FEM class 1Bm (M3 acc. to DIN EN 818-7) must be reduced. Use a lifting point with a higher WLL.
- During attaching and unhinging of lifting means (chain sling) no crushing, tripping or shearing actions may occur.
- Eliminate damaging of lifting means caused by sharp edges
- Prior to loading adjust the ACP lifting point towards the direction of the load force.

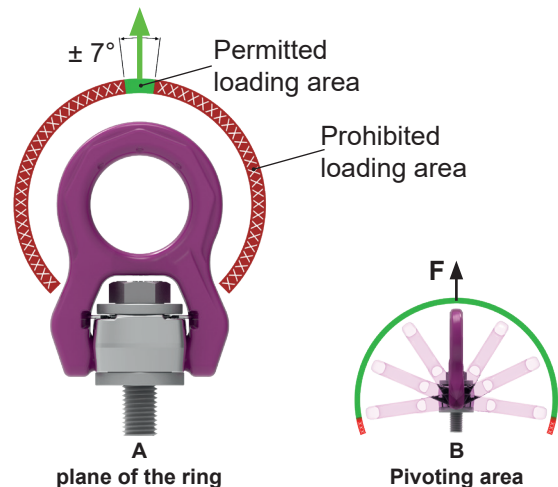

Pic. 4: *

A: Prohibited lateral force in plane of the ring

B: Permitted load direction in pivoting area

* Fig. 4 shows the design of the ACPM12-M30 resp. $1/2''$ - $1 1/4''$. The load areas also apply for the ACPM36-M42 and $1 1/2''$ - $1 3/4''$ respectively.

- Observe that the lifting mean is freely movable within the suspension ring of the ACP.

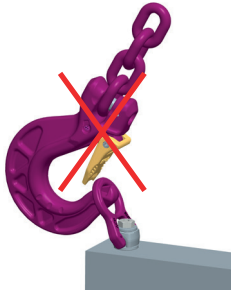

Pic. 5: Only use suitable lifting means for the hinging at the ACP.

- Any bending force at the suspension ring is prohibited.

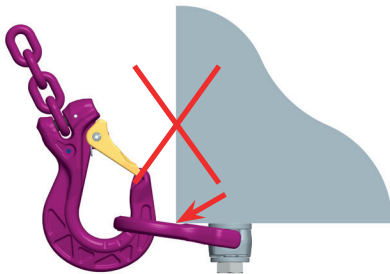

Pic. 6: The suspension ring must be freely movable and not touch the edge of the load.

- Make sure that the lifting point is fully engaged into the tapped hole

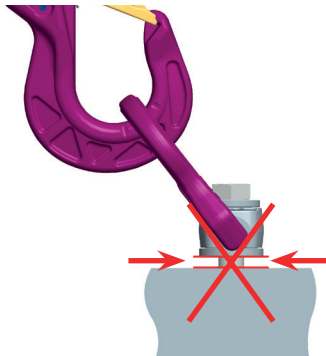

Pic. 7: The lifting point must have been fully bolted in.

3.3.2 General information regarding the spring

The spring keeps the suspension ring away from the shaded area shown in Fig. 7. As a matter of fact this avoids prohibited side loading of the ring in the 90 ° direction (see section 3.3.1, Pic. 4). Under load the force of the spring will be overbored and the ACP can be loaded in the vertical direction. The pivoting of the suspension ring is possible with an increased hand force.



Pic. 8: Detailed view of spring ACP M12-M30 or 1/2"-1 1/4"

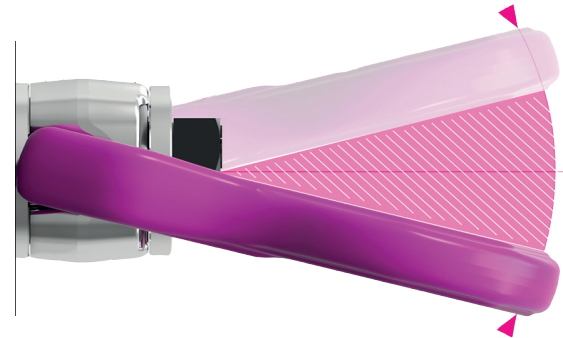

Pic. 9: The spring keeps the suspension ring out of the shaded area.

3.3.3 Permitted lifting and turning actions

The following turning actions are permitted:

- Turning of load while suspension ring is pivoted in the direction of the load force.



WARNING

The suspension ring must not get in touch with the edge of the load or other attachments

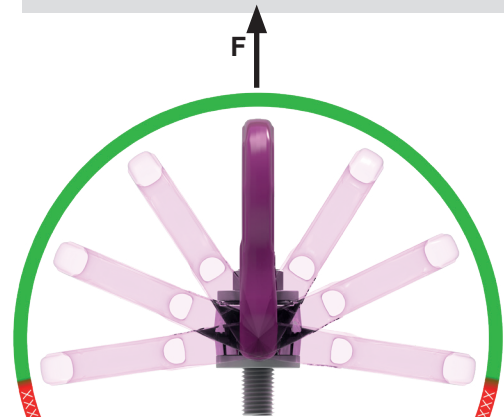

Pic. 10: Pivoting area (green = permitted loading direction)



WARNING

Prior to each lifting or turning action check torque of the bolt.

- After a max. turn of 180°, the torque of the bolt must be checked.
- Turning around the bolt axle under load, with the exception of section 3.3.4, is permissible.

3.3.4 Prohibited lifting and turning actions

The following actions are prohibited:



WARNING

Do not rotate the ACP under load in the direction of the bolt axle ($\pm 15^\circ$).



Pic. 11: Prohibited rotation under load in the direction of the bolt axle.

- Not suitable for permanent turning actions under load.

3.4 Disassembly / assembly of the RUD bolt

| The following figures show the design of the ACP M12-M30 or $1\frac{1}{2}$ "-1 $\frac{3}{4}$ ". The disassembly / assembly of the RUD screw works in the same way for the ACP M36-M42 or 1 $\frac{1}{2}$ "-1 $\frac{3}{4}$ ". |



NOTE

Disassembly/assembly to either replace or check the bolt must be carried out by a competent person!

3.4.1 Disassembly of the bolt

1. Position the ACP upside down to the left and right of the bolt head at the bush on a support (e.g. vice). Attention: Do not clamp head of bolt!
2. Slightly hammer on the end of the bolt to punch the bolt out from the bushing (Pic. 12). Attention: In doing so, the thread must not be damaged!



Pic. 12: Supporting position of the ACP on of the vice jaws

3.4.2 Assembly of the bolt



NOTE

Only the correct bolt type (strength class) acc. to the corresponding size must be used!

M12-M24 or $1\frac{1}{2}$ "-1": ICE-BOLT only

M30-M42 or 1 $\frac{1}{4}$ "-1 $\frac{3}{4}$ ": 10.9 bolt

1. Insert the bolt into the bushing with insertion bevel (see Pic. 13).

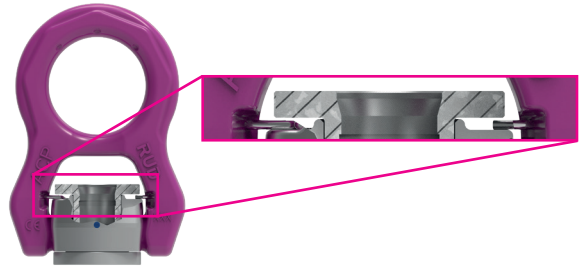

Pic. 13: ACP cross section. You can see the insertion bevel at the top of the bush

2. Insert the bolt into the bush so that the circlip has been fully positioned in a recess of the bush (see Pic. 14).



HINT

Finally turn the bolt until the circlip sits properly in the groove!



Pic. 14: Circlip fully positioned in the recess of the countersink

3. Apply light beats on the bolt head to insert the bolt and to make sure that the bearing surface of the bolt sits on top of the bushing.
4. Subsequently check if the bolt is captive and can be turned easily. Bolt must rotate easily by 360°.

4 Inspection / Repair / Disposal

4.1 Hints for the regularly inspection

The operator has to determine and dictate the necessary inspection periods and the deadlines by a risk assessment (see sections 4.2 and 4.3).

The persisting appropriateness of the lifting point must be checked by a competent person (auditor) at least once per year.

Depending on the conditions of use e.g. frequent use, increased wear or corrosion, it may be necessary to carry out inspections at shorter intervals than once per year. A verification is also required following damage and after special events.

The operator must specify the test cycles.

4.2 Inspection criteria for the regularly examination carried out by the operator:

- Correct bolt and nut size, bolt quality grade and thread engagement length
- Observe proper tightening of bolt. Check torque value.
- Completeness of the lifting point.
- Check readability of WLL statement and manufacturer sign
- Deformations at load bearing areas like body, suspension ring and bolt.
- Mechanical damage like notches especially at areas with tensile stress.
- Easy turning of the ACP around the bolt axle must be guaranteed.
- Function of the spring (suspension ring must be kept away from vertical position, see section 3.3.2, *Pic. 9*).

4.3 Additional inspection criteria for the competent person resp. auditor

- Reduction of cross section cause by wear of more than 10 %
- Strong corrosion
- Function and damage at bolts, nuts and as well at the tapped hole (*3.4 Disassembly / assembly of the RUD bolt*).
- Additional inspections may be necessary depending on the result of the risk assessment (e.g. incipient cracks at load bearing parts).

4.4 Disposal

Dispose worn out components / attachments or packaging according to the local waste removal requirements.

5 Tables/Overview

Type	weight [kg]	A [mm]	B [mm]	C [mm]	D [mm]	E [mm]	F [mm]	F _{max} [mm]	G [mm]	H [mm]	K [mm]	L [mm]	L _{max} [mm]	M	N [mm]	I [mm]	T [mm]	torque [Nm]	Ref.-No.	
																			with bolt	Vario
ACP M12	0.37	--	11	10.5	38	30	19	117	28	54.5	58	47	145	M12	8	19	83	80	7909314	8600632
ACP M16	0.82	--	14	14	50	40	22	149	36	68	76	58	185	M16	10	24	107	150	7909316	8600634
ACP M20	1.34	--	17	17.25	50	45	26.5	186.5	43.5	82.5	89	70	230	M20	12	30	118	300	7909317	8600636
ACP M24	3.03	--	23	23	66	60	34	210	55	104	121	89	265	M24	14	36	154	500	7909318	8600638
ACP M30	5.66	--	29	27	75	75	41.5	271.5	68.5	129	148	110	340	M30	17	46	183	800	7909319	8600640
ACP M36	7.1	106	32	32	82	70	45	240	60	128	168	105	300	M36	22	55	189	800	7911052	8600642
ACP M42	7.5	106	32	32	82	70	53	290	60	136	168	113	350	M42	24	65	189	1500	7911053	8600644
Type	weight [kg]	A [mm]	B [mm]	C [mm]	D [mm]	E [mm]	F [mm]	F _{max} [mm]	G [mm]	H [mm]	K [mm]	L [mm]	L _{max} [mm]	M	N [mm]	I [mm]	T [mm]	torque [Nm]	Ref.-No.	
ACP 1/2"	0.37	--	11	10.5	38	30	18	124.4	28	54	58	46	152.4	1/2"	5/16"	3/4"	83	80	7909417	8600632
ACP 5/8"	0.82	--	14	14	50	40	22	148.5	36	68	76	58	184	5/8"	3/8"	15/16"	107	150	7909418	8600634
ACP 3/4"	1.34	--	17	17.25	50	45	25.5	185	43.5	81	89	69	228.6	3/4"	1/2"	1 1/8"	118	300	7909419	8600636
ACP 1"	3.15	--	23	23	66	60	36	199	55	105.5	121	91	254	1"	9/16"	1 1/2"	154	500	7909420	8600638
ACP 1 1/4"	5.77	--	29	27	75	75	46.5	271	68.5	134.5	148	115	339.5	1 1/4"	5/8"	1 7/8"	183	800	7909421	8600640
ACP 1 1/2"	7.3	106	32	32	82	70	48	287	60	131	168	108	347	1 1/2"	7/8"	2 1/4"	189	800	7911054	8600643
ACP 1 3/4"	7.7	104	32	32	82	70	56	290	60	141	168	117	350	1 3/4"	1"	2 5/8"	189	1500	7911055	--

Table 2: Overview of dimensions

We reserve the right to make technical changes

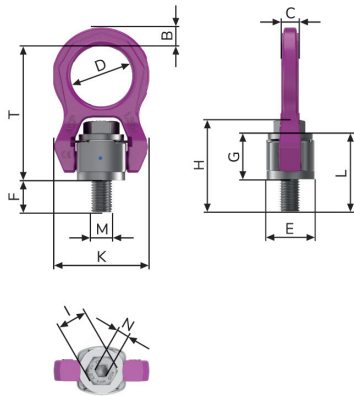

Pic. 15: ACP M12-M30 or 1/2"-1 1/4"

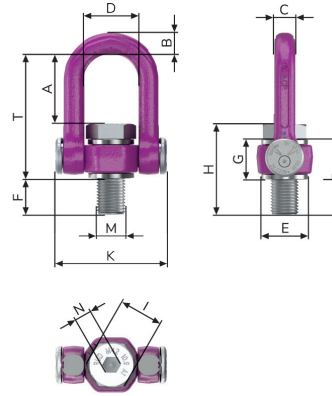

Pic. 17: ACP M36-M42 or 1 1/2"-1 3/4"

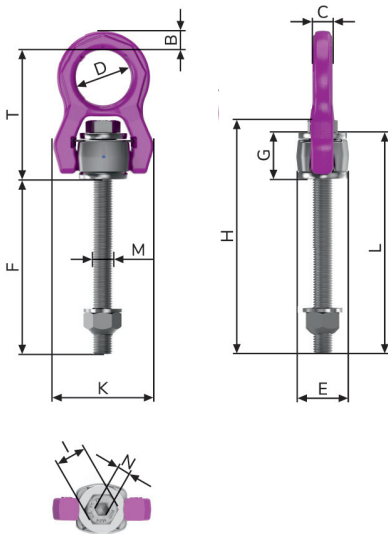

Pic. 16: ACP VARIO M12-M30 or 1/2"-1 1/4"

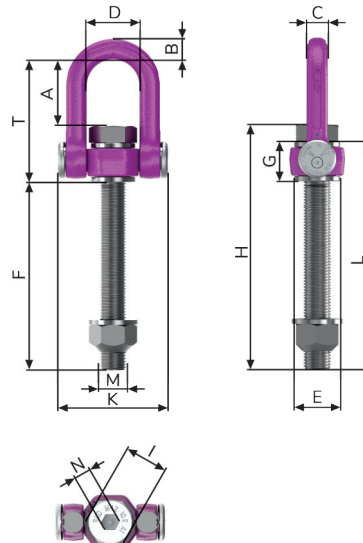

Pic. 18: ACP VARIO M36-M42 or 1 1/2"-1 3/4"

Diagram											
Lifting method											
Number of legs	1	1	2	2	2	2	2	3 / 4	3 / 4	3 / 4	
Inclination angle β	0°-7°	90°	0°-7°	90°	0-45°	>45-60°	Unsymm.	0-45°	>45-60°	Unsymm.	
Factor	1	1	2	2	1.4	1	1	2.1	1.5	1	
Safety factor 4:1	Safety factor 4:1 für max. Gesamt-Lastgewicht in Tonnen. festgeschraubt und in Zugrichtung eingestellt										
	ACP M12 / 1/2"	1.35	1.35	2.7	2.7	1.9	1.35	1.35	2.84	2	1.35
	ACP M16 / 5/8"	2.5	2.5	5	5	3.5	2.5	2.5	5.25	3.75	2.5
	ACP M20 / 3/4"	4	4	8	8	5.6	4	4	8.4	6	4
	ACP M24 / 1"	6.3	6.3	12.6	12.6	8.8	6.3	6.3	13.2	9.5	6.3
	ACP M30 / 1 1/4"	8	8	16	16	11.2	8	8	17	11.8	8
	ACP M36	15	12.5	30	25	17	12.5	12.5	26.5	19	12.5
	ACP M42	18	16	36	32	22.4	16	16	33.6	24	16
	ACP 1 1/2"	16	14	32	28	19.6	14	14	29.4	21	14
	ACP 1 3/4"	18	16	36	32	22.4	16	16	33.6	24	16
	Safety factor 4:1 For max. total load in lbs. bolted and adjusted to the direction of pull										
	ACP M12 / 1/2"	2970	2970	5940	5940	4200	2970	2970	6300	4450	2970
	ACP M16 / 5/8"	5500	5500	11000	11000	7770	5500	5500	11660	8250	5500
	ACP M20 / 3/4"	8820	8820	17640	17640	12470	8820	8820	18710	13230	8820
ACP M24 / 1"	13890	13890	27780	27780	19440	13890	13890	29460	20830	13890	
ACP M30 / 1 1/4"	17630	17630	35260	35260	24930	17630	17630	37400	26440	17630	
ACP M36	33070	27550	66140	55100	38960	27550	27550	58440	41320	27550	
ACP M42	39680	35270	79360	70540	49870	35270	35270	74810	52900	35270	
ACP 1 1/2"	35270	30860	70540	61720	43640	30860	30860	65460	46290	30860	
ACP 1 3/4"	39680	35270	79360	70540	49870	35270	35270	74810	52900	35270	
Safety factor 5:1	Safety factor 5:1 For max. total load in metric tons. bolted and adjusted to the direction of pull										
	ACP M12 / 1/2"	1.1	1.1	2.2	2.2	1.5	1.1	1.1	2.3	1.6	1.1
	ACP M16 / 5/8"	2	2	4	4	2.8	2	2	4.25	3	2
	ACP M20 / 3/4"	3.2	3.2	6.4	6.4	4.5	3.2	3.2	6.7	4.8	3.2
	ACP M24 / 1"	5	5	10	10	7.1	5	5	10.6	7.5	5
	ACP M30 / 1 1/4"	6.4	6.4	12.8	12.8	9	6.4	6.4	13.5	9.6	6.4
	ACP M36	12	10	24	20	14	10	10	21	15	10
	ACP M42	14.4	12.8	28.8	25.6	18	12.8	12.8	26.9	19.2	12.8
	ACP 1 1/2"	12.8	11.2	25.6	22.4	15.7	11.2	11.2	23.5	16.8	11.2
	ACP 1 3/4"	14.4	12.8	28.8	25.6	18	12.8	12.8	26.9	19.2	12.8
	Safety factor 5:1 For max. total load in lbs. bolted and adjusted to the direction of pull										
	ACP M 12 / 1/2"	2380	2380	4760	4760	3360	2380	2380	5040	3570	2380
	ACP M 16 / 5/8"	4400	4400	8800	8800	6220	4400	4400	9330	6600	4400
	ACP M 20 / 3/4"	7040	7040	14080	14080	9950	7040	7040	14930	10560	7040
ACP M 24 / 1"	11080	11080	22160	22160	15670	11080	11080	23500	16620	11080	
ACP M 30 / 1 1/4"	14080	14080	28160	28160	19910	14080	14080	29860	21120	14080	
ACP M36	26450	22040	52900	44080	31160	22040	22040	46750	33060	22040	
ACP M42	31740	28220	63480	56440	39900	28220	28220	59860	42330	28220	
ACP 1 1/2"	28220	24690	56440	49380	34910	24690	24690	52370	37030	24690	
ACP 1 3/4"	31740	28220	63480	56440	39900	28220	28220	59860	42330	28220	
At a lift with one strand and two parallel strands where the inclination angles are at the max.± 7°. the lifting methode can be assumed as a vertical lift.					When lifting with two, three or four leg lifting means. inclination angles of less than 15° shall be avoided. if possible (Risk of instability).						

Table 3: Working load limit in metric tons (top) and in lbs (bottom)