

# NITCHI

LEVER HOIST  
RB5

---

SERVICE MANUAL No.1

---

 **NICH CO., LTD.**  
OSAKA, JAPAN.

---

## Contents

---

1. Precautions .....	1
2. Daily inspections .....	1
3. Periodic inspections .....	3
4. Disassembly .....	10
4-1. Disassembly procedures (0.5t) .....	10
4-2. Disassembly procedures (0.8 - 6.3t) .....	12
4-3. Disassembly procedures of Operating handle (0.8 - 6.3t) .....	13
4-4. Disassembly procedures of Bottom hook assembly (6.3t) .....	14
5. Assembly .....	15
5-1. Assembly procedures (0.5t) .....	15
5-2. Assembly procedures (0.8 - 6.3t) .....	18
5-3. Assembly procedures of Operating handle (0.8 - 6.3t) .....	21
5-4. Assembly procedures of Bottom hook assembly (6.3t) .....	22
6. Parts list .....	23
7. F-OLP Unit (Overload protection device) .....	26
7-1. Assembly procedures .....	26
7-2. Parts list .....	27

---

## 1. Precautions

- Never inspect or service when Lever hoist is under a load.
- Always remove dirt on Load sheave, Load chain or other components after disassembly.
- Replace all the spare parts which is deformed, worn or corrosive with new ones.
- Never use other than NITCHI genuine parts.

## 2. Daily inspections

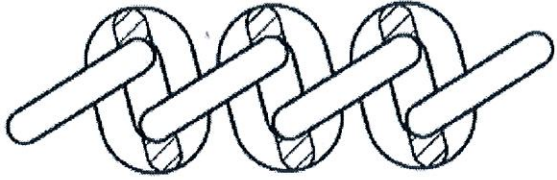
Category	Inspection points	Inspection method	Permissive limit for use and/or Criteria	Measures
Marking	Name plate (p/114)	Inspect visually	Name plate must be fixed securely and legible.	Stop the operation of subjected unit and pass it on to maintenance.
Hook	Hook opening	Inspect visually	The opening must not be increased.	
	Deformation	Inspect visually	There must be no bend nor twist.	
	Deformation at shank	Inspect visually	There must be no excessive space between the hook shank and the holder.	
	Rotation of shank	Check its movement	The hook must rotate smoothly.	
	Wear and corrosion	Inspect visually	There must be no excessive wear nor corrosion.	
	Cracks and other dangerous flaw	Inspect visually	The hook must be free of cracks and other dangerous flaws.	
	Safety latch assembly (p/74)	Inspect visually and check its movement.	There must be no excessive wear nor deformation, and it must function properly.	
Load chain	Pitch elongation	Inspect visually	The link pitch must not be elongated excessively.	
	Wear of link diameter	Inspect visually	The link diameter must not be worn excessively. (Refer to Fig.1)	
				<p><b>Fig. 1</b> The shaded portion much tends to get worn.</p>
	Deformation	Inspect visually	There must be no deformation.	
	Cracks and other dangerous flaws	Inspect visually	The load chain must be free of cracks and other dangerous flaws	
	Corrosion	Inspect visually	There must be no excessive corrosion.	

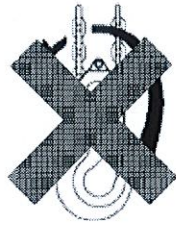
Category	Inspection points	Inspection method	Permissive limit for use and/or Criteria	Measures
Main body	Side-plates (p/18,20)	Inspect visually	The plates must be free of deformation nor of excessive corrosion.	Stop the operation of subjected unit and pass it on to maintenance.
	Gear cover (p/37)	Inspect visually	The gear cover must be free of excessive deformation nor corrosion.	
	Stop grip assembly (p/16)	Inspect visually	1) Confirm that the Stop grip is positively connected to the end of the Load chain. 2) The Stop grip must not be deformed.	
Nuts & Bolts etc.	Nuts and bolts of each section.	Inspect visually	There must be no missing bolts, nuts nor revets which are visible from the outside, and all of them must be tightly fastened.	
	Lifting & Lowering	Lift & lower a light load	1) Clicking sound of the brake ratchet must be heard at lifting operation positively. 2) Both of lifting and lowering operations must be smooth. 3) The brake must operate without malfunctioning at lowering.	
	Selector device	Check the function	Switching to lifting, lowering and free-wheeling must be done properly and smoothly.	
	Free-wheeling	Check the function	Free-wheeling operation must be done smoothly.	
	Twisting of Load chain and turning of bottom hook through two falls of the Load chain	Inspect visually and check by operation	1) There must be no twist nor kink of Load chain at lifting or lowering operation. 2) In case of 6.3t capacity, there must be no twist of Load chain caused by the bottom hook turning through the two falls. 	
			Fig.2	

### 3. Periodic inspections

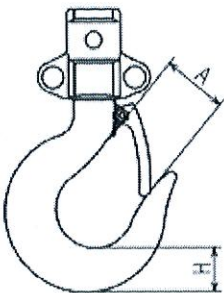
Category	Inspection points	Inspection method	Permissive limit for use and/or Criteria	Measures																												
Marking	Name plate (p/114)	Inspect visually	The hoist must be always in the presence of Name plate at its position.	Put a Name plate.																												
Hook	Hook opening	Measure dimension.	The hook opening at dimension A in Fig.3 has to be within the criteria as shown in Table 1 as under.	Replace with a new complete hook assembly.																												
	Wear and corrosion	Inspect visually & measure dimension	1) The thickness of hook at dimension H must be within the criteria in Table 1. 2) There must be no excessive corrosion.																													
	 <p>Fig. 3</p>																															
	<table border="1"> <thead> <tr> <th rowspan="2">Capacity (ton)</th> <th>A</th> <th colspan="2">H</th> </tr> <tr> <th>Std. Dimension</th> <th>Std. Dimension</th> <th>Criteria</th> </tr> </thead> <tbody> <tr> <td>0.5</td> <td>30</td> <td>17</td> <td>16.2 or over</td> </tr> <tr> <td>0.8</td> <td>30</td> <td>20</td> <td>19.0 or over</td> </tr> <tr> <td>1.6</td> <td>36</td> <td>26.5</td> <td>25.2 or over</td> </tr> <tr> <td>3.2</td> <td>42</td> <td>35</td> <td>33.3 or over</td> </tr> <tr> <td>6.3</td> <td>52</td> <td>52</td> <td>49.4 or over</td> </tr> </tbody> </table>				Capacity (ton)	A	H		Std. Dimension	Std. Dimension	Criteria	0.5	30	17	16.2 or over	0.8	30	20	19.0 or over	1.6	36	26.5	25.2 or over	3.2	42	35	33.3 or over	6.3	52	52	49.4 or over	
	Capacity (ton)	A	H																													
		Std. Dimension	Std. Dimension		Criteria																											
	0.5	30	17		16.2 or over																											
0.8	30	20	19.0 or over																													
1.6	36	26.5	25.2 or over																													
3.2	42	35	33.3 or over																													
6.3	52	52	49.4 or over																													
<p>Table 1 Hooks dimensions &amp; criteria (Unit: mm)</p>																																
	Deformation	Inspect visually	There must be no bend nor twist on the hook.																													
	Deformation at shank	Inspect visually	There must be no excessive space between the hook shank and the holder.																													
	Rotation of Hook	Inspect visually	The hook must rotate smoothly.																													
	Cracks and other dangerous flaw	Inspect visually	The hook must be free of cracks and other dangerous flaws.																													
	Safety latch assembly (p/74)	Inspect visually and check its movement.	There must be no excessive wear nor deformation, and it must function properly.	Replace safety latch assembly or complete Hook assembly.																												
	Elongation of the hole for Load chain fastening bolt (p/124)	Measure dimension	1) The elongation must be within 0.5 mm. 2) The hole must not be deformed to be an oval shape.	Replace complete Hook assembly with new one.																												

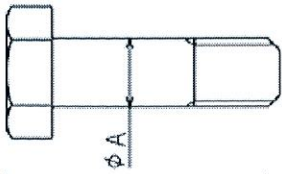
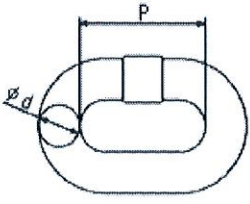
Category	Inspection points	Inspection method	Permissive limit for use and/or Criteria	Measures																													
Hook	Chain fastening bolt (p/124)	Inspect visually & measure dimension	1) Diameter A of Chain fastening bolt in Fig 4 must remain within the criteria of Table 2. 2) There must be no deformation nor damage on the bolt.	Replace with a new part.																													
	 Fig. 4		<table border="1"> <thead> <tr> <th rowspan="2">Capacity (ton)</th> <th colspan="2"><math>\phi A</math></th> </tr> <tr> <th>Std. Dimension</th> <th>Criteria</th> </tr> </thead> <tbody> <tr> <td>0.5</td> <td>5.0</td> <td>4.8 or over</td> </tr> <tr> <td>0.8</td> <td>7.0</td> <td>6.6 or over</td> </tr> <tr> <td>1.6</td> <td>8.5</td> <td>8.0 or over</td> </tr> <tr> <td>3.2 • 6.3</td> <td>13.0</td> <td>12.5 or over</td> </tr> </tbody> </table>	Capacity (ton)	$\phi A$		Std. Dimension	Criteria	0.5	5.0	4.8 or over	0.8	7.0	6.6 or over	1.6	8.5	8.0 or over	3.2 • 6.3	13.0	12.5 or over													
Capacity (ton)	$\phi A$																																
	Std. Dimension	Criteria																															
0.5	5.0	4.8 or over																															
0.8	7.0	6.6 or over																															
1.6	8.5	8.0 or over																															
3.2 • 6.3	13.0	12.5 or over																															
	Yoke pin (p/51)	Inspect visually	Yoke pin must be free of excessive wear, deformation nor of other damages.	Replace with a new part.																													
Load chain	Deformation	Inspect visually	Each link of the Load chain must be free of deformation.	Replace with new one. Also, replace Load sheave when Load chain is replaced. (Refer to Note 1, Page 9.)																													
	Cracks and other dangerous flaws	Inspect visually	Each link of the Load chain must be free of cracks and other dangerous flaws.																														
	Corrosion	Inspect visually	There must be no corrosion nor rust generated on the Load chain.																														
	Elongation of link pitch	Measure dimension	The pitch dimension P in Fig. 5 of the Load chain must not exceed the limits in Table 3.																														
	Wear	Measure dimension	The diameter d in Fig. 5 of the Load chain must be within the criteria in Table 3.																														
	 Fig. 5		<table border="1"> <thead> <tr> <th rowspan="2">Capacity (ton)</th> <th colspan="2"><math>\phi d</math></th> <th colspan="2">P</th> </tr> <tr> <th>Std. Dimension</th> <th>Criteria</th> <th>Std. Dimension</th> <th>Criteria</th> </tr> </thead> <tbody> <tr> <td>0.5</td> <td>4.0</td> <td>3.6 or over</td> <td>12.2</td> <td>12.8 or less</td> </tr> <tr> <td>0.8</td> <td>5.6</td> <td>5.1 or over</td> <td>17.1</td> <td>17.9 or less</td> </tr> <tr> <td>1.6</td> <td>7.1</td> <td>6.4 or over</td> <td>21.2</td> <td>22.2 or less</td> </tr> <tr> <td>3.2 • 6.3</td> <td>9.0</td> <td>8.1 or over</td> <td>27.2</td> <td>28.5 or less</td> </tr> </tbody> </table>	Capacity (ton)	$\phi d$		P		Std. Dimension	Criteria	Std. Dimension	Criteria	0.5	4.0	3.6 or over	12.2	12.8 or less	0.8	5.6	5.1 or over	17.1	17.9 or less	1.6	7.1	6.4 or over	21.2	22.2 or less	3.2 • 6.3	9.0	8.1 or over	27.2	28.5 or less	
Capacity (ton)	$\phi d$		P																														
	Std. Dimension	Criteria	Std. Dimension	Criteria																													
0.5	4.0	3.6 or over	12.2	12.8 or less																													
0.8	5.6	5.1 or over	17.1	17.9 or less																													
1.6	7.1	6.4 or over	21.2	22.2 or less																													
3.2 • 6.3	9.0	8.1 or over	27.2	28.5 or less																													
	Table 3 Load chain dimensions (Unit: mm)																																

Category	Inspection points	Inspection method	Permissible limit for use and/or Criteria	Measures
	Side plates (p/18,20)	Inspect visually	The Side plates must be free of deformation nor of excessive corrosion.	Replace with a new part.
	Gear cover (p/37)	Inspect visually	Gear cover must be free of deformation nor of excessive corrosion.	Replace with a new part.
	Load sheave (p/5)	Inspect visually & measure dimension	<ol style="list-style-type: none"> <li>1) The pocket (portion A) in Fig. 6 of Load sheave must be free of deformation.</li> <li>2) The dimension B in Fig.6 must be within the criteria in Table 4.</li> <li>3) The dimension C in Fig.6 must be within the criteria in Table 4.</li> <li>4) There must be no dangerous flaws like a crack or other damages.</li> <li>5) The multiple thread portion and the serration must be free of excessive wear, deformation, scratch or of other flaws.</li> </ol>	Replace with a new part. Also, replace Load chain when Load sheave is replaced. (Refer to Note 1, Page 9.)

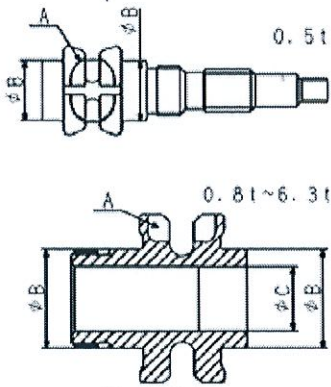

Fig. 6



Main body

Capacity (ton)	φB		φC	
	Std. Dimension	Criteria	Std. Dimension	Criteria
0.5	24.7	24.0 or over	—————	
0.8	28.3	27.6 or over	18.2	18.7 or less
1.6	31.0	30.3 or over	18.3	18.8 or less
3.2 • 6.3	40.0	39.1 or over	21.4	21.9 or less

Table 4 Dimensions, Load sheave

(Unit: mm)

Chain guide (p/12)	Inspect visually	Chain guide must be free of excessive wear, deformation or of other damages.	Replace with a new part.
Pinion shaft washer (p/59)	Inspect visually	Pinion shaft washer must be free of excessive wear, deformation or of other damages.	Replace with a new part.
Idle sheave (p/55)	Inspect visually	<ol style="list-style-type: none"> <li>1) Idle sheave must be free of excessive wear or deformation.</li> <li>2) There must be no crack nor other flaws.</li> </ol>	Replace with a new part.
Operating handle (p/24)	Inspect visually	<ol style="list-style-type: none"> <li>1) Operating handle must be free of excessive wear or deformation.</li> <li>2) There must be no scratch nor other flaws.</li> </ol>	Replace with a new one.

Category	Inspection points	Inspection method	Permissive limit for use and/or Criteria	Measures																			
Main body	Free-wheeling spring (p/106)	Inspect visually	Free-wheeling spring must be free of excessive deformation, wear or of other flaws.	Replace with a new part.																			
	Bushings on Gear cover (p/n 37) & Side plates (p/18,20)	Inspect visually	1) The holes must not be deformed to be oval. 2) The bushings must be free of dangerous flaws like wear, crack or other damages.	Replace complete Side plates or Gear cover.																			
	Stop grip assembly (p/16)	Inspect visually	1) Confirm the presence of Stop grip assembly. 2) Stop grip assembly must be free of deformation.	Replace with a new part.																			
Nuts & bolts etc.	Nuts, bolts, rivets & washers of each section	Inspect visually	Confirm existence of all the nuts, bolts, rivets & plain washers at internal and external sections on each positions. They all must be free of damages and be tightened securely.	Replace with new ones.																			
Brake	Brake lining (p/105)	Inspect visually & measure dimension	1) Check the wear. Thickness $t$ of Brake lining in Fig. 7 must be within the criteria of Table 5. 2) Brake lining must be free of fracture, crack or of scratch due to foreign materials.	Replace with new ones.																			
	 <p>Fig. 7</p> <table border="1" data-bbox="756 1205 1299 1391"> <thead> <tr> <th rowspan="2">Capacity (ton)</th> <th colspan="2"><math>t</math></th> </tr> <tr> <th>Std. Dimension</th> <th>Criteria</th> </tr> </thead> <tbody> <tr> <td>0.5~0.8</td> <td>3.0</td> <td>2.5 or over</td> </tr> <tr> <td>1.6~6.3</td> <td>3.5</td> <td>3.0 or over</td> </tr> </tbody> </table> <p>Table 5 Dimensions, Brake lining (Unit: mm)</p>	Capacity (ton)	$t$		Std. Dimension	Criteria	0.5~0.8	3.0	2.5 or over	1.6~6.3	3.5	3.0 or over	<table border="1" data-bbox="756 1644 1299 1830"> <thead> <tr> <th rowspan="2">Capacity (ton)</th> <th colspan="2"><math>\phi A</math></th> </tr> <tr> <th>Std. Dimension</th> <th>Criteria</th> </tr> </thead> <tbody> <tr> <td>0.5~0.8</td> <td>35.9</td> <td>36.6 or less</td> </tr> <tr> <td>1.6~6.3</td> <td>27.2</td> <td>27.9 or less</td> </tr> </tbody> </table> <p>Table 6 Dimensions, Ratched wheel (Unit: mm)</p>	Capacity (ton)	$\phi A$		Std. Dimension	Criteria	0.5~0.8	35.9	36.6 or less	1.6~6.3	27.2
Capacity (ton)	$t$																						
	Std. Dimension	Criteria																					
0.5~0.8	3.0	2.5 or over																					
1.6~6.3	3.5	3.0 or over																					
Capacity (ton)	$\phi A$																						
	Std. Dimension	Criteria																					
0.5~0.8	35.9	36.6 or less																					
1.6~6.3	27.2	27.9 or less																					
	Pawl (p/7) and Ratchet wheel (p/9)	Inspect visually & measure dimension	1) The internal diameter $A$ of Ratchet wheel in Fig. 8 must not excess the limit in Table 6. 2) Pawl and Ratchet wheel must be free of excessive wear.	Replace with new ones.																			
	 <p>Fig. 8</p>																						

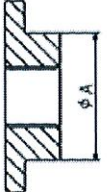
Category	Inspection points	Inspection method	Permissible limit for use and/or Criteria	Measures										
Brake	Disc hub (p/8)	Inspect visually & measure dimension	1) The diameter A of Disc hub in Fig. 9 must be within criteria in Table 7. 2) There must be no deformation, scratch nor other damage on the part.	Replace with a new part.										
	 <p>Fig. 9</p>		<table border="1" data-bbox="753 555 1295 743"> <thead> <tr> <th rowspan="2">Capacity (ton)</th> <th colspan="2">φA</th> </tr> <tr> <th>Std. Dimension</th> <th>Criteria</th> </tr> </thead> <tbody> <tr> <td>0.5~0.8</td> <td>35.6</td> <td>34.9 or over</td> </tr> <tr> <td>1.6~6.3</td> <td>27.0</td> <td>26.3 or over</td> </tr> </tbody> </table> <p>Table 7 Dimensions, Disc hub (Unit: mm)</p>	Capacity (ton)	φA		Std. Dimension	Criteria	0.5~0.8	35.6	34.9 or over	1.6~6.3	27.0	26.3 or over
Capacity (ton)	φA													
	Std. Dimension	Criteria												
0.5~0.8	35.6	34.9 or over												
1.6~6.3	27.0	26.3 or over												
Gears	Pinion shaft (p/1)	Inspect visually	1) The gear teeth must be free of tiers or scratches. 2) There must be no excessive wear nor damage. 3) The sections of multiple thread and serration must be free of excessive wear, deformation, scratch or other flaws.	Replace with a new part.										
	Pinion with pinion gear (p/2)	Inspect visually	1) The gear teeth must be free of tiers or scratches. 2) There must be not excessive wear nor damage. 3) The pressed-in portion must be free of looseness, deformation nor of other damages.	Replace with new ones.										
	Load gear (p/4)	Inspect visually	1) The gear teeth must be free of tiers or scratches. 2) There must be no excessive wear nor other damages.	Replace with a new part.										
	Disc nut (p/23)	Inspect visually	1) There must be no excessive wear, deformation, scratch nor other damages. 2) The section of multiple thread must be free of excessive wear, deformation, scratch nor other damages.	Replace with a new part.										
	Friction gear (p/82) <Overload protection device>	Inspect visually	The gear teeth must be free of excessive wear, deformation, scratch nor other damages.	Replace with a new part.										

Category	Inspection points	Inspection method	Permissive limit for use and/or Criteria	Measures																		
Operation	Lifting & lowering	Lift and lower with a light load.   <b>Fig. 10</b>	<ol style="list-style-type: none"> <li>1) Clicking sound of the brake ratchet must be heard at lifting operation positively.</li> <li>2) Both of lifting and lowering operations must be smooth.</li> <li>3) The brake must operate without malfunctioning at lowering.</li> <li>4) In case of 6.3t capacity, there must be no twist of Load chain caused by the bottom hook turning through the two falls as per Fig. 10.</li> </ol>	Disassembly and fix the flaw.																		
	Functions	<p>Test twice the cycle of lifting and lowering in accordance with Table 8 (Test load) and Table 9 (Testing distance)</p> <p>Test at the rated load in case of a unit with Overload protection device.</p>	<ol style="list-style-type: none"> <li>1) Confirm Load chain and Load sheave mesh properly with each other.</li> <li>2) Confirm gears mesh each other properly and smoothly.</li> <li>3) Brake must work positively and securely.</li> <li>4) The load chain must be free of twists nor kinks both at lifting and lowering.</li> <li>4) There must be no remarkable change of the levering force in lifting.</li> </ol>																			
<p><b>Table 8 Test load (Unit: t)</b></p> <table border="1"> <thead> <tr> <th>Rated load</th> <th>0.5</th> <th>0.8</th> <th>1.6</th> <th>3.2</th> <th>6.3</th> </tr> </thead> <tbody> <tr> <th>Test load</th> <td>0.75</td> <td>1.2</td> <td>2.4</td> <td>4.8</td> <td>7.9</td> </tr> </tbody> </table> <p><b>Table 9 Testing distance</b></p> <table border="1"> <thead> <tr> <th>Nos. of chain falls</th> <th>Test. Distance</th> </tr> </thead> <tbody> <tr> <td>1 fall</td> <td>300 mm</td> </tr> <tr> <td>2 falls</td> <td>150 mm</td> </tr> </tbody> </table> <p>1 test cycle = One shuttling operation of up and down.</p>					Rated load	0.5	0.8	1.6	3.2	6.3	Test load	0.75	1.2	2.4	4.8	7.9	Nos. of chain falls	Test. Distance	1 fall	300 mm	2 falls	150 mm
Rated load	0.5	0.8	1.6	3.2	6.3																	
Test load	0.75	1.2	2.4	4.8	7.9																	
Nos. of chain falls	Test. Distance																					
1 fall	300 mm																					
2 falls	150 mm																					
	Selector device	Operate by hand	The selector device must move and switch smoothly.																			
	Free-wheeling	Operate by hand	Free-wheeling must be achieved smoothly.																			

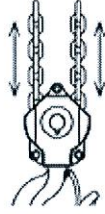
Category	Inspection points	Inspection method	Permissive limit for use and/or Criteria	Measures
Operation	Rotation of Idle sheave (p/55)	Hold two falls of the Load chain by each hand and pull them up and down alternately, to confirm smooth rotation of Idle sheave. (Refer to Fig.11)	Idle sheave must rotate smoothly.  Fig. 11	Disassembly and repair.
	Overload protection device	Load-test	<ol style="list-style-type: none"> <li>1) The rated load in Table 8 must be lifted up surely.</li> <li>2) Then test with a load of twice the rated load. Overload protection device must function properly so not to lift the test load.</li> <li>3) Lowering operation must be done securely under the load.</li> </ol>	<p>Disassembly and adjust. Disassembly and adjust.</p> <p>Replace defective parts and adjust.</p>

Note 1. In case either the Load chain or Load sheave is to be replaced, replace both parts at the same time. They are fatal and counterparts each other.

Note 2. The load tests under periodic inspection must be conducted, not before, but after the individual components have been investigated and corrected.

Note 3. Consult authorized NITCHI agent or distributor for the adjustment of Overload protection device.

## 4. Disassembly

### 4 - 1. Disassembly procedures (0.5t)

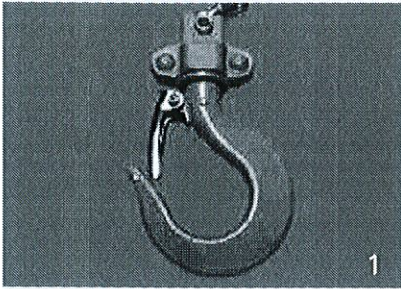

1  
Disconnect (p/53) Bottom hook assembly.

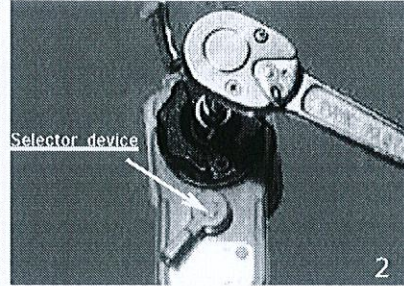

2  
Turn Selector device to UP position and untighten (p/120) Nylon nut.

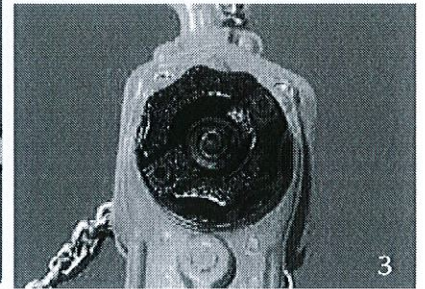

3  
Take (p/119) Plain washer off.

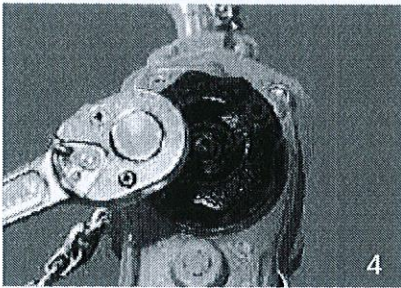

4  
Loosen and remove (p/128) Hex.socket head cap screw.



5  
Take off (p/42) Guide handle.

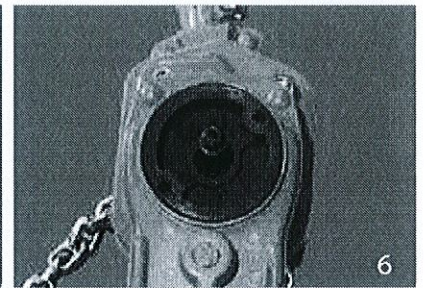

6  
Remove (p/106) Free-wheeling spring.

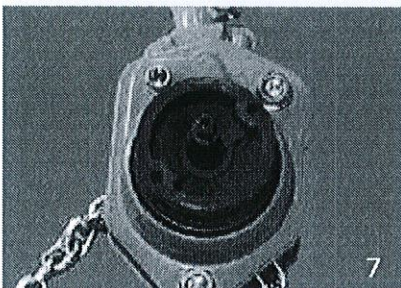

7  
Dismantle (p/24) Operating handle.



8  
Remove (p/23) Disc nut.

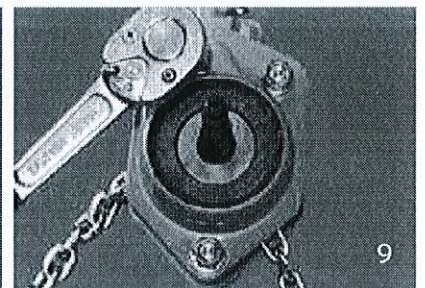

9  
Loosen (p/126) Lock nut.

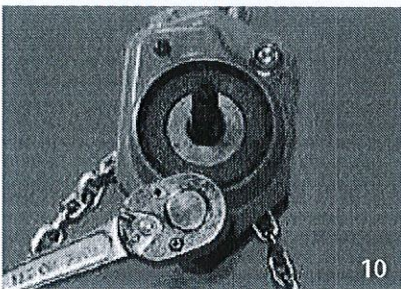

10  
Loosen (p/107) Spring nut.

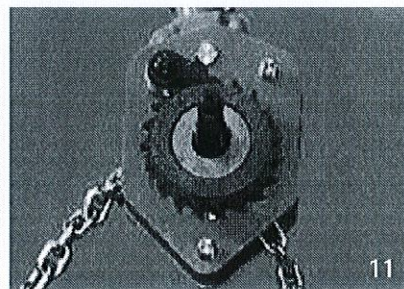

11  
Take off (p/40-1) Ratchet cover.

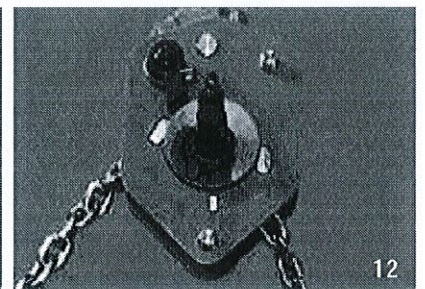

12  
Pull brake assembly [(p/8) Disc hub, (p/105) Brake lining & (p/9) Ratchet wheel] out from (p/5) Load sheave.

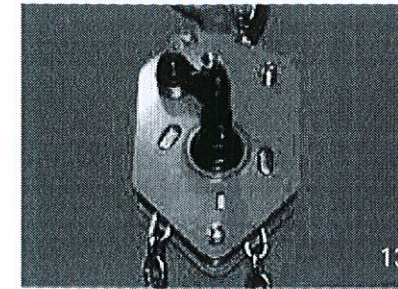

Remove (p/108) Coned disc spring.

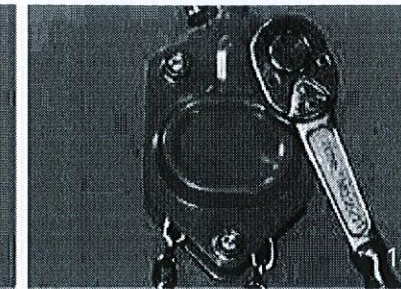

Reverse the body, and loosen (p/107) Spring nut.

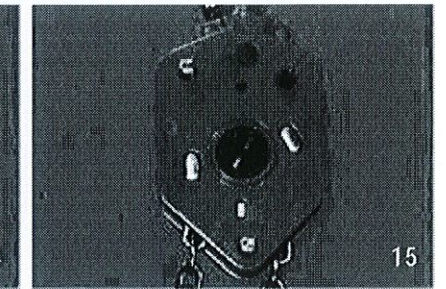

Remove (p/36) Body cover.

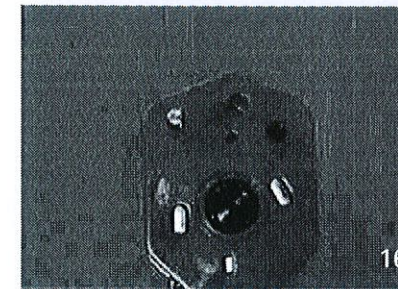

Pull (p/51) Yoke pin out and detach (p/48) Top hook assembly.

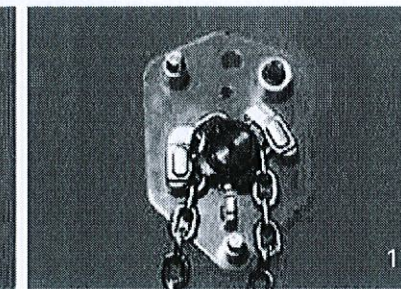

Dismount (p/18) Plain-side plate assembly.

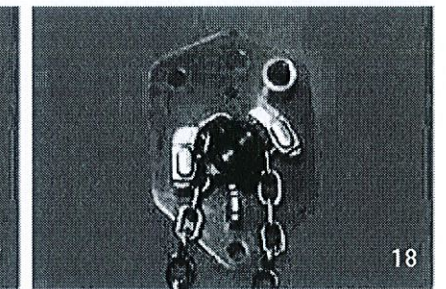

Take (p/20-3) Stay bolt off.

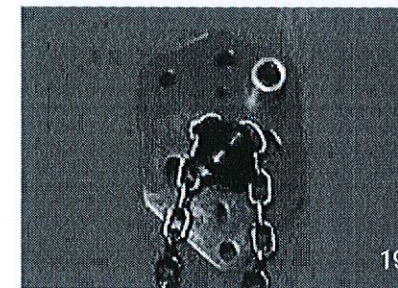

Detach (p/15) Stripper and (p/12) chain guides.

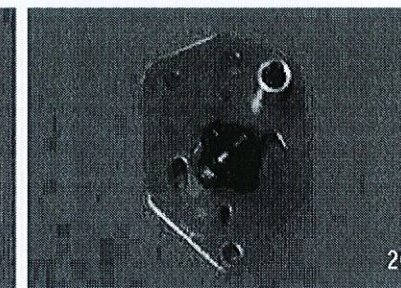

Remove load chain [(p/6) Load chain and (p/16) Stop grip].

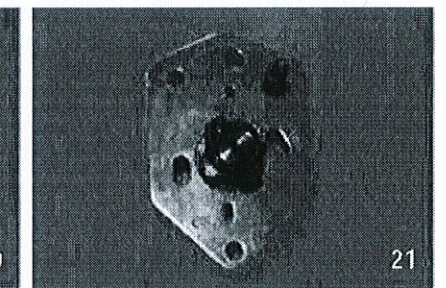

Take (p/10) Stay pipe off.

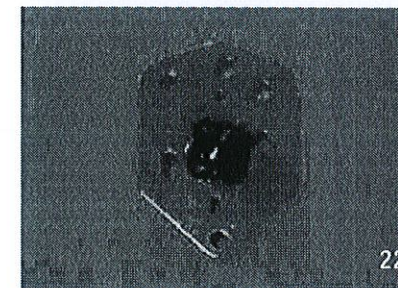

Detach (p/19) Stay bolt for pawl, (p/104) Pawl spring and (p/103) Retaining ring-E type.

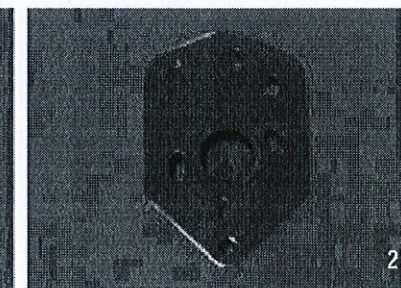

Remove (p/5) Load sheave.

## 4 - 2. Disassembly procedures(0.8~6.3t)

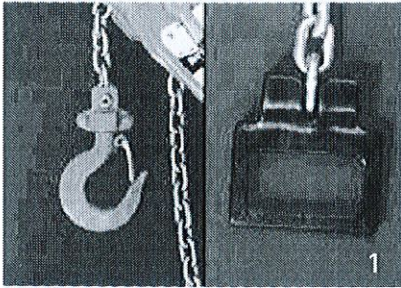

1  
Disconnect (p/53) Bottom hook assembly & (p/16) Stop grip assembly from Load chain.

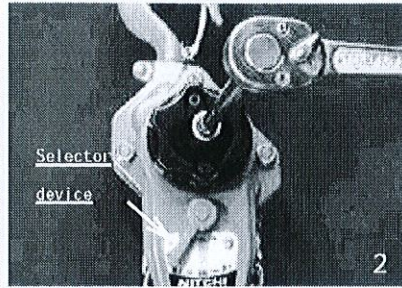

2  
Turn Selector device to UP position and untighten (p/120) Nylon nut.

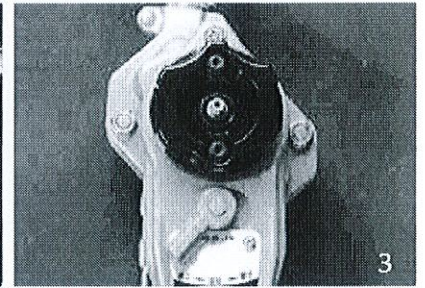

3  
Take (p/119) Plain washer off.

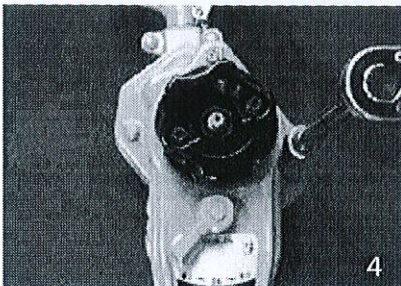

4  
Loosen (p/107) Spring nut.

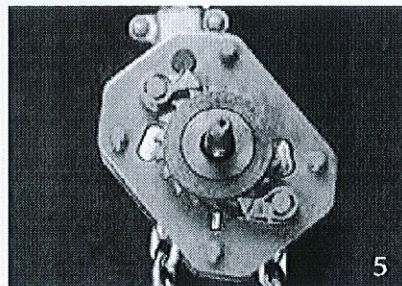

5  
Turn Selector device to free-wheeling ( N ) position, then dismantle (p/24) operating handle while turning (p/42) Guide handle anti-clockwise.



6  
Pull brake assembly [(p/8) Disc hub, (p/105) Brake lining & (p/9) Ratchet wheel] out from (p/1) Pinion shaft.

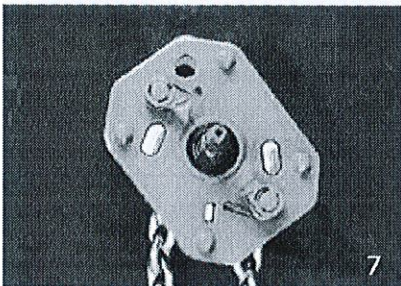

7  
Pick (p/51) Yoke pin out and remove (p/48) Top hook assembly.

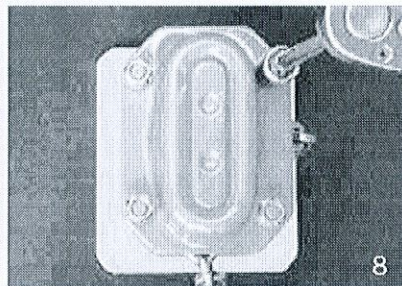

8  
Reverse main body and loosen (p/107) Spring nuts.

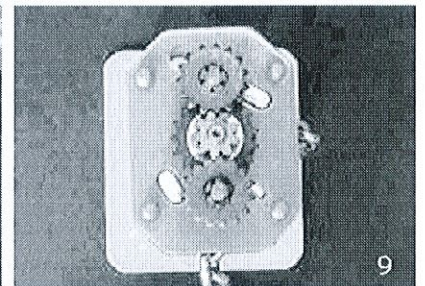

9  
Dismantle (p/37) Gear cover.

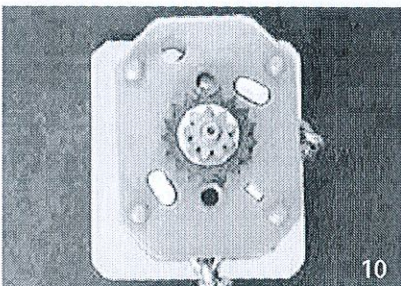

10  
Take two (p/2) Pinion with pinion gear off.

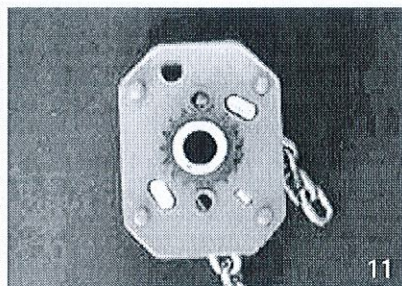

11  
Pull out (p/1) Pinion shaft.

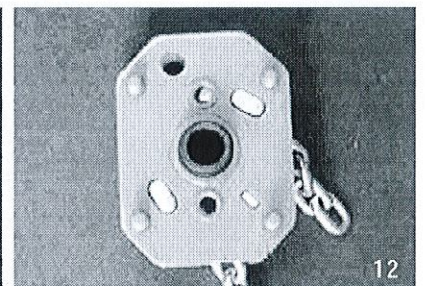

12  
Detach (p/59) Pinion shaft washer and (p/4) Load gear.

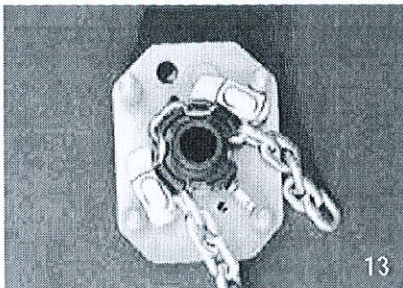

Dismount (p/18) Gear-side plate assembly.

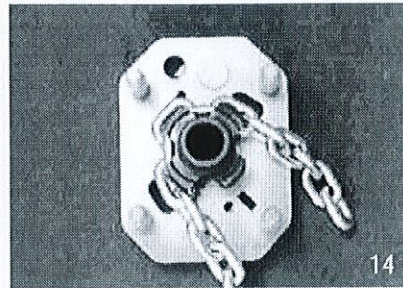

Detach (p/12) Chain guide and (p/15) Stripper.

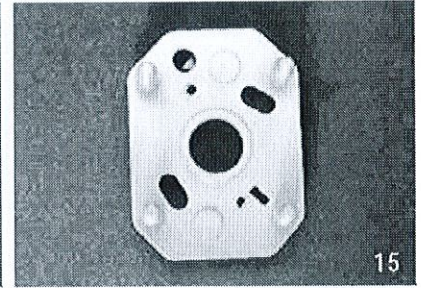

Remove (p/6) Load chain and (p/5) Load sheave.

### 4 - 3. Disassembly procedures of Operating handle(0.8~6.3t)

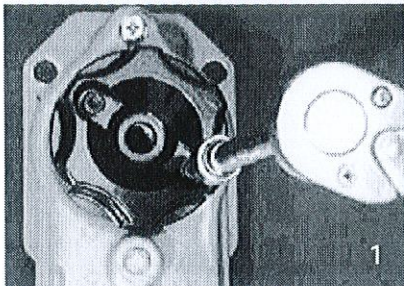

Loosen and remove (p/128) Hex.socket head cap screw.

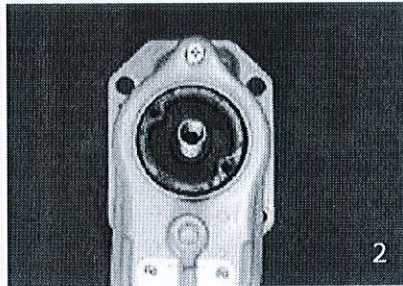

Remove (p/42) Guide handle.

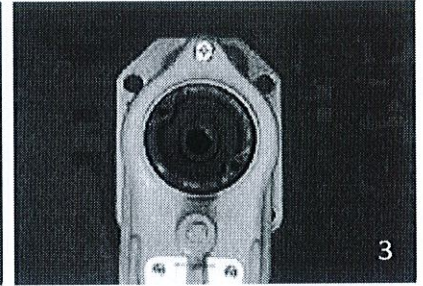

Pick up (p/106) Free-wheeling spring.

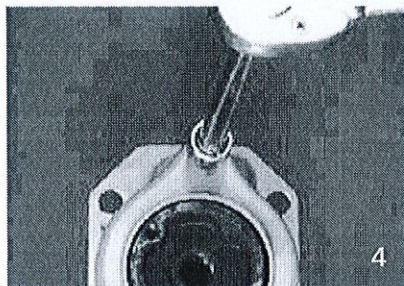

Unscrew (p/113) Upset head bolt.

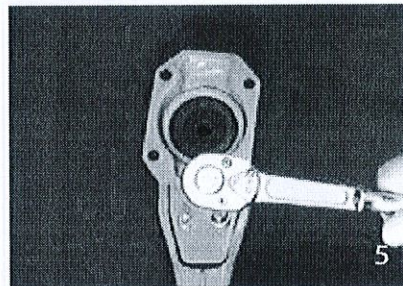

Loosen (p/111) Spring nut.

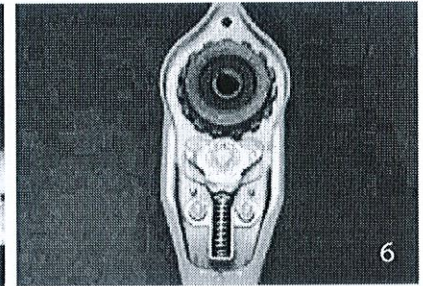

Dismantle (p/40) Ratchet cover assembly.

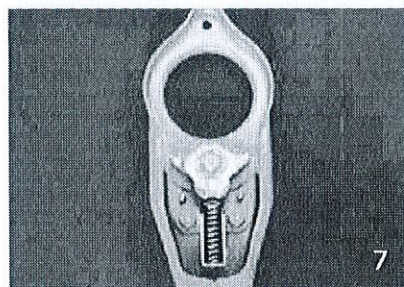

Remove (p/23) Disc nut.

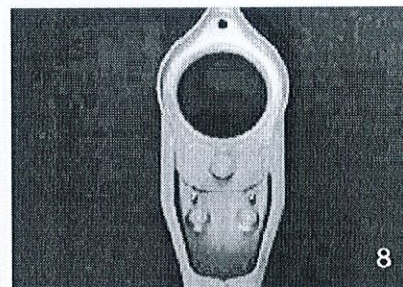

Detach (p/30) Spring shaft, (p/101) Change-over spring, (p/31) Shaft base and (p/32) Handle pawl.

#### 4 - 4. Disassembly procedures of Bottom hook assembly(6.3t)

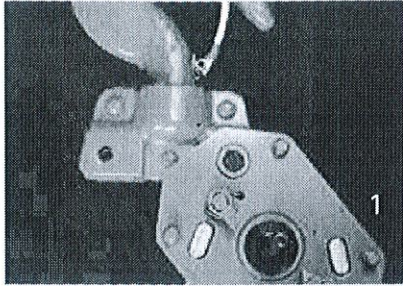

Loosen (p/124) Chain fastening bolt, to unchain (p/53) Bottom hook assembly by pulling the Load chain out.

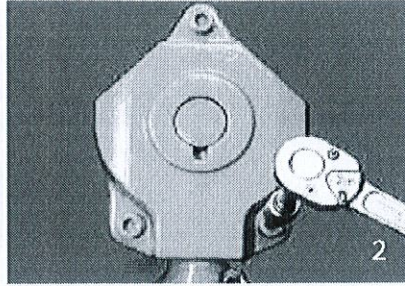

Loosen (p/142) Spring nut and detach (p/141) Hex. socket head cap screw.

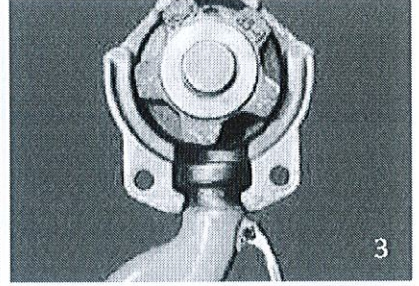

Take off (p/53-3) Tail holder.

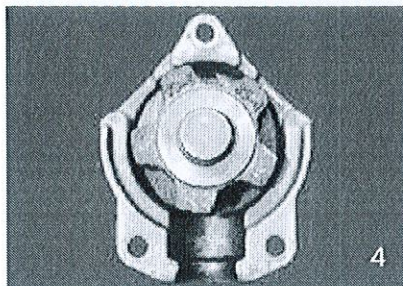

Remove Bottom hook.

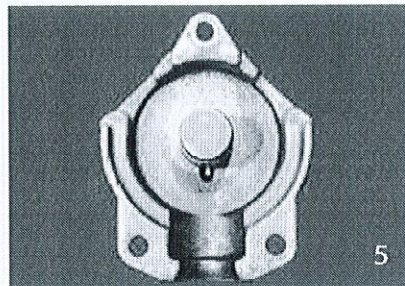

Detach (p/58) Collar for idle sheave and (p/55) Idle sheave.

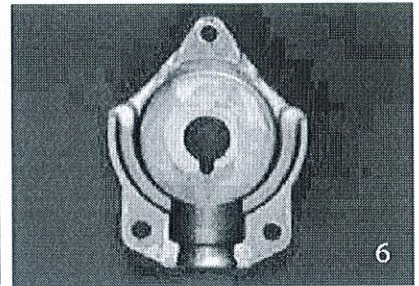

Remove (p/56) Wheel pin.

## 5. Assembly

### 5 - 1. Assembly procedures(0.5t)

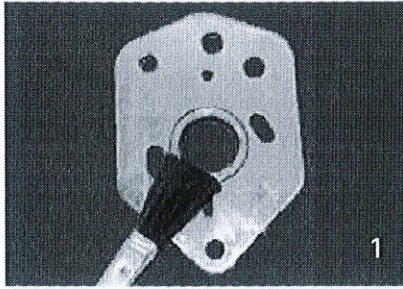

Grease at load metal of (p/20) Handle-side plate assembly.  
[NOTE] Rest the plate so that the side of the collar of load metal appears up.

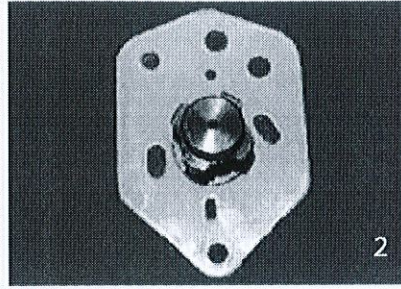

Fit (p/5) Load sheave.

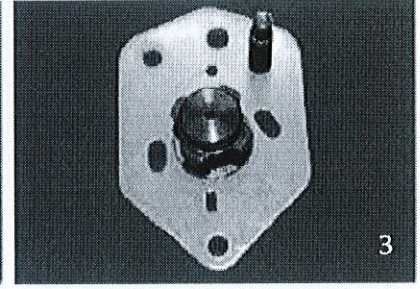

Insert (p/19) Stay bolt for pawl from the reverse side of (p/20) Handle-side plate. (Make sure of its direction.)

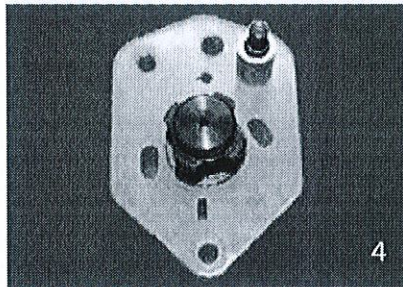

Insert (p/10) Stay pipe over (p/19) Stay bolt for pawl.

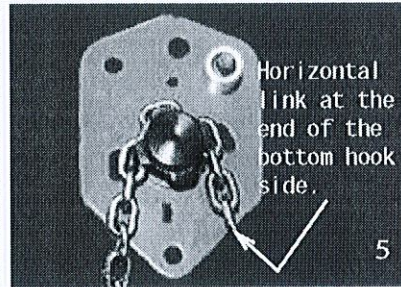

Fit (p/6) Load chain with (p/16) Stop grip on (p/5) Load sheave. Make sure the weld-abutment of vertical links face the outside and the load chain ends up with a horizontal link to attach the bottom hook.

Cf. *Vertical link*: The link which is fed vertically to the groove of load sheave.  
*Horizontal link*: The link which is fed horizontally to the pocket of load sheave.

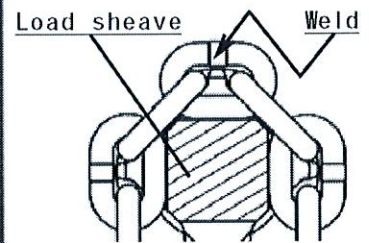
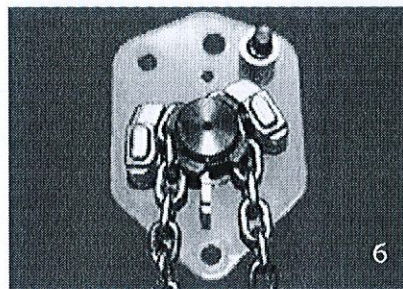
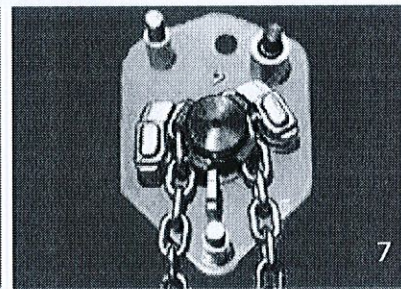

Fig.12 Load chain direction



Mount (p/12) Chain guides & (p/15) Stripper on (p/20) Handle-side plate assembly in the directions as shown in the above photo.



Mount (p/20-3) Stay bolt on (p/20) Handle-side plate assembly.

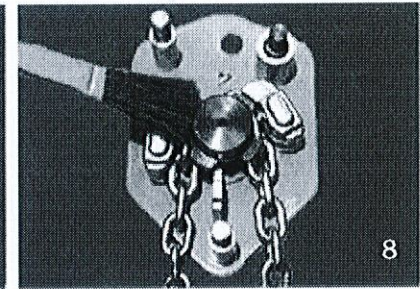

Grease to the shank part of (p/5) Load sheave.

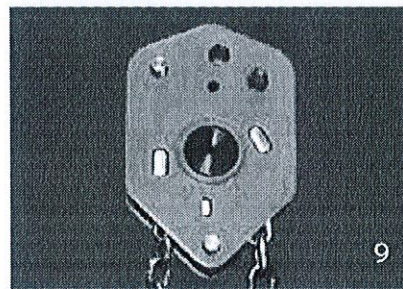

Fit (p/18) Plain-side plate assy so as the collar of its load metal is located at the reverse side.

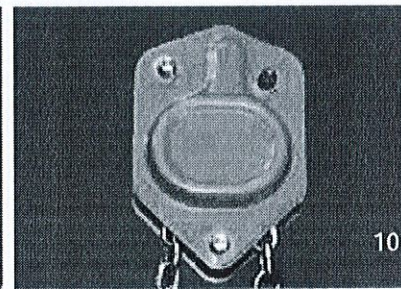

Place (p/36) Body cover in position.

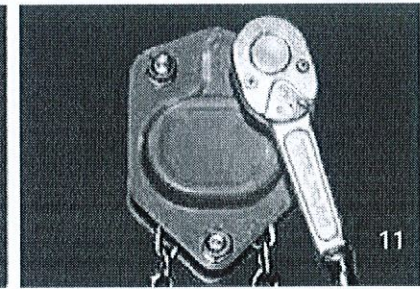

Tighten up with (p/107) Spring nuts.



12  
Place (p/48) Top hook assy in between the side plates and insert (p/51) Yoke pin to hold it.

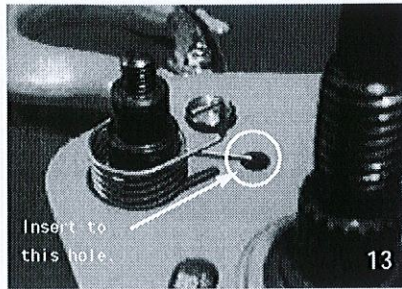

13  
Fit (p/104) Pawl spring on (p/19) Stay bolt for pawl, then put one end of the spring into the hole of (p/20) Handle side plate assembly. (Be careful of the spring direction.)

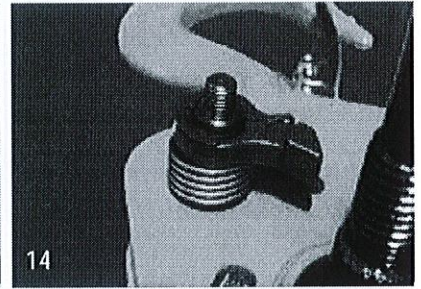

14  
Set (p/7) Pawl on (p/19) Stay bolt for pawl, and fix it with (p/103) Retaining ring-E type.

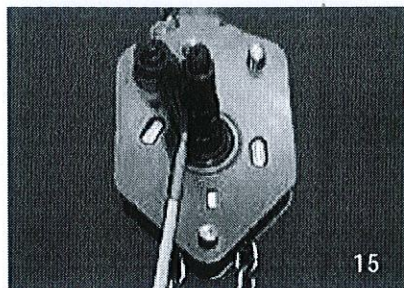

15  
Grease multi-thread part of (p/5) Load sheave.

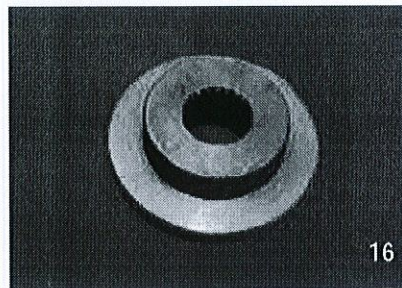

16  
Be sure to keep (p/8) Disc hub away from any grease/oil material.

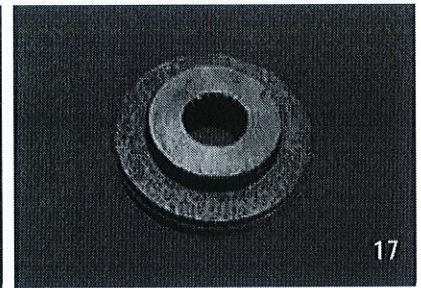

17  
Fit (p/105) Brake lining. (Keep any grease/oil away.)

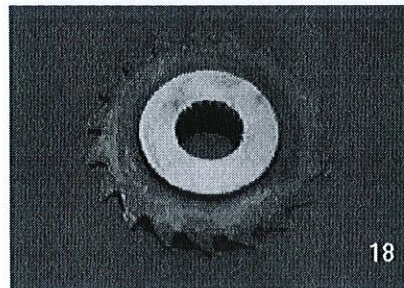

18  
Grease slightly on the sliding surface of inner hole of (p/9) Ratchet wheel, then to mount it. (Be sure of the ratchet direction.)

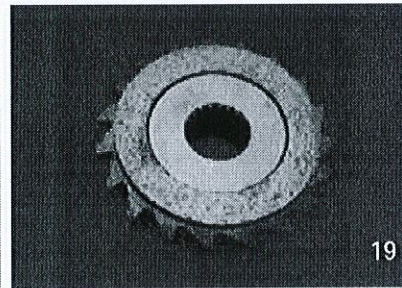

19  
Mount (p/105) Brake lining. (Keep any grease/oil away from the brake unit other than process 18.)

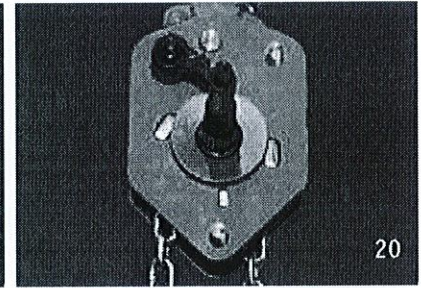

20  
Insert (p/108) Coned disc spring through load sheave.

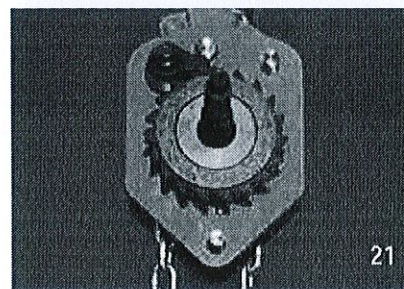

21  
Attach complete brake assembly [(p/8) Disc hub, (p/105) Brake linings & (p/9) Ratchet wheel] on the main body. Then set Pawl tip on the ratchet tooth.

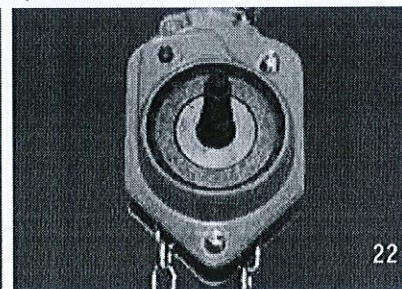

22  
Set (p/40-1) Ratchet cover.

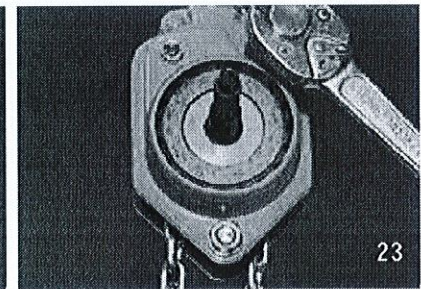

23  
Tighten up with (p/126) Lock nut and (p/107) Spring nuts.

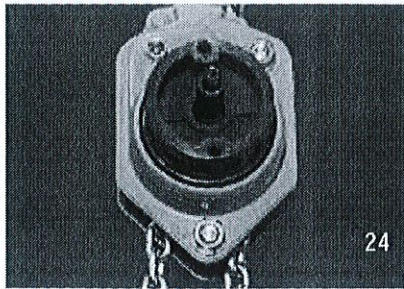

Fit (p/23) Disc nut.

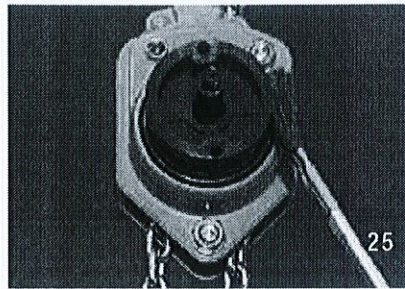

Grease to the side face of (p/23) Disc nut.

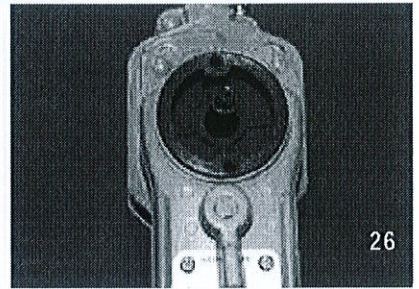

Attach (p/24) Operating handle.

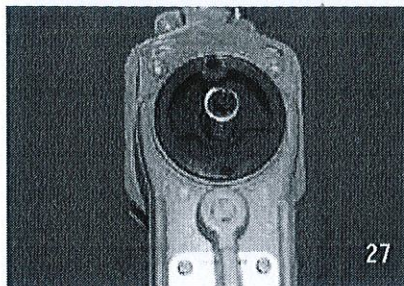

Put (p/106) Free-wheeling spring.

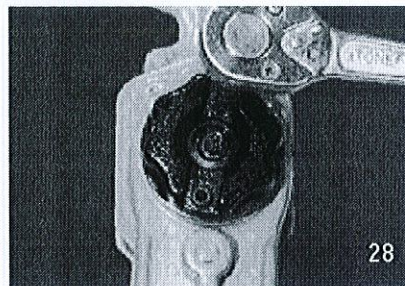

Mount (p/42) Guide handle and fix it with (p/128) Hex. socket head cap screws.

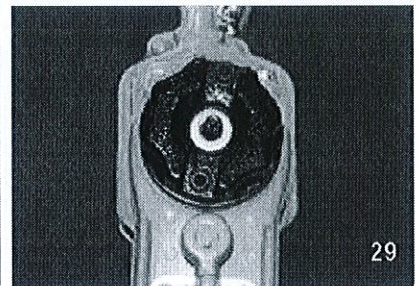

Set (p/119) Plain washer.

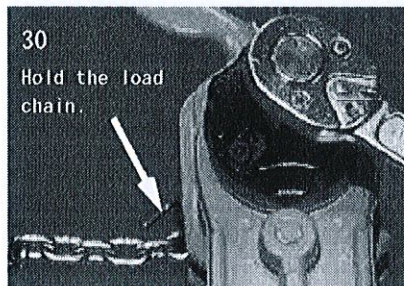

30  
Hold the load chain.



Connect (p/53) Bottom hook assembly with (p/124) Chain fastening bolt.

Turn Selector device to the Free-wheeling ( N ) position and tighten up with (p/120) Nylon nut. At this procedure, be sure to hold the load chain with a jig, and fasten the Nylon nut securely.

## 5 - 2 . Assembly procedures(0.8~6.3t)

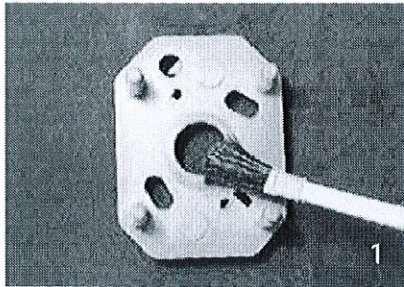

Grease load metal of (p/20) Handle-side plate assembly.

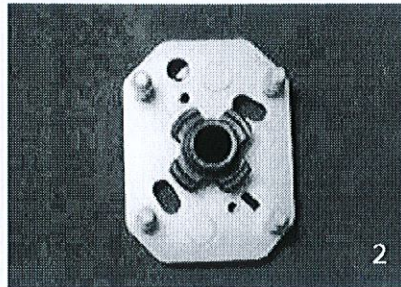

Attach (p/5) Load sheave.

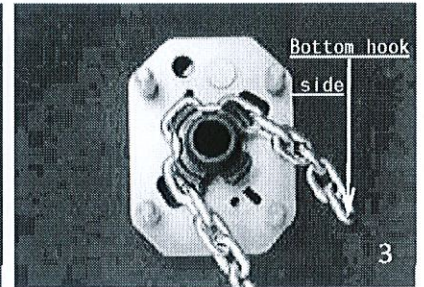

Fit (p/6) Load chain on (p/5) Load sheave. Make sure the weld-abutment of vertical links face the outside. **【Refer to Fig.12 on P.15】**

The load chain on the side of bottom hook ends up with a horizontal link for 0.8t -3.2t and with vertical link for 6.3t.

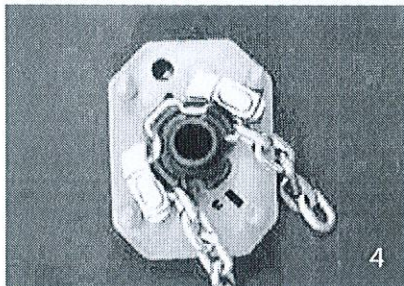

Mount (p/12) Chain guide on (p/20) Handle-side plate assembly.

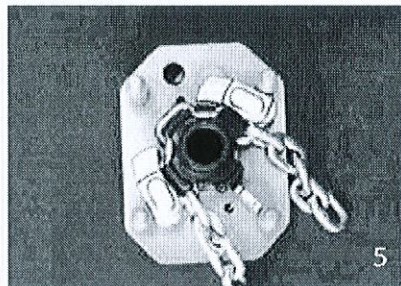

Mount (p/15) Stripper on (p/20) Handle-side plate assembly.

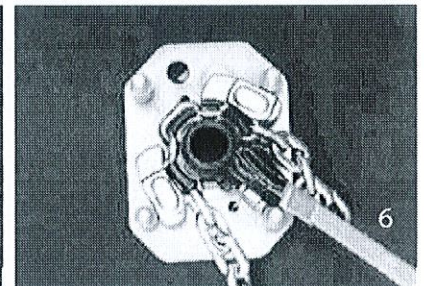

Grease to the shank part of (p/5) Load sheave.

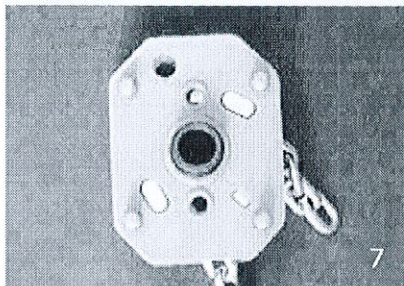

Fit (p/18) Gear-side plate assembly.

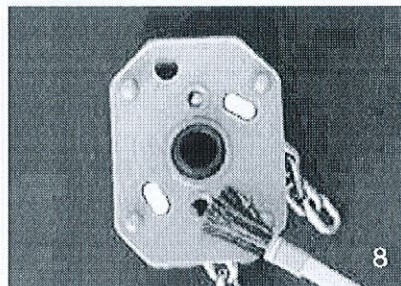

Grease to pinion metal of (p/18) Gear-side plate assembly.

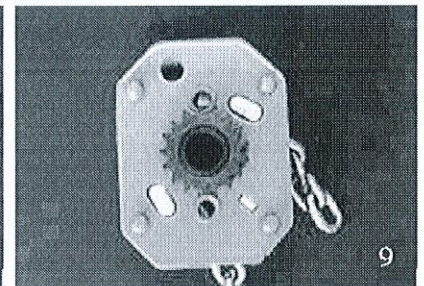

Install (p/4) Load gear.

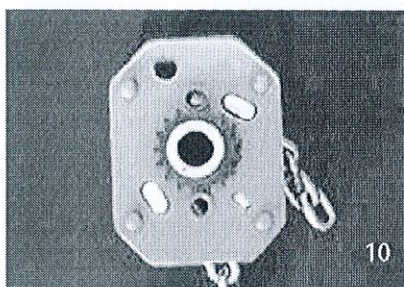

Set (p/59) Pinion shaft washer.

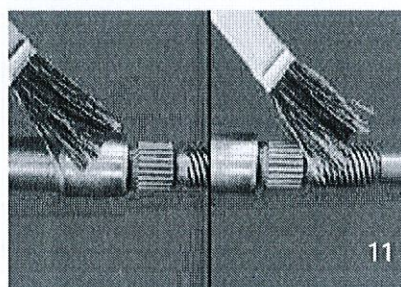

Grease to shank and multi-thread portion of (p/1) Pinion shaft.

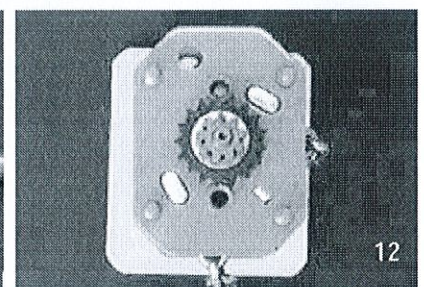

Insert (p/1) Pinion shaft.

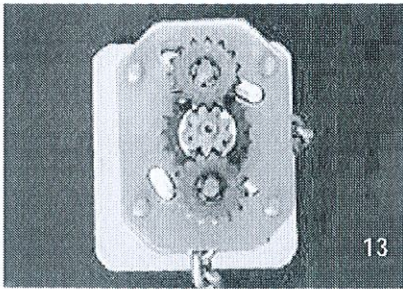

Mount two (p/2) Pinion with pinion gear.

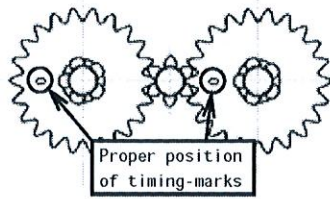
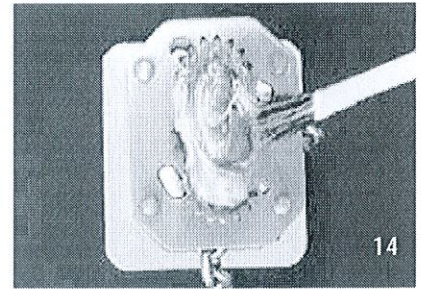
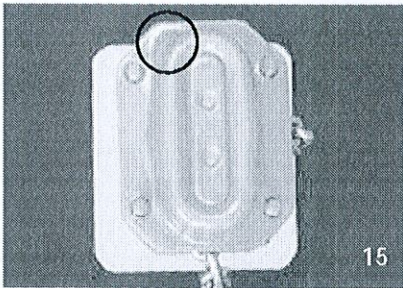

Fig.13 Timing-marks of pinions

In meshing the pinions, make sure to adjust the timing-marks as the above Fig.13 (1.6t~6.3t).



Grease enough at gears and shank sections. (0.8t~70g, 1.6t~100g, 3.2t~6.3t~140g)



Set (p/37) Gear cover. Be sure of the correct direction. (Match the above-circled point with the hole for p/51 Yoke pin.)

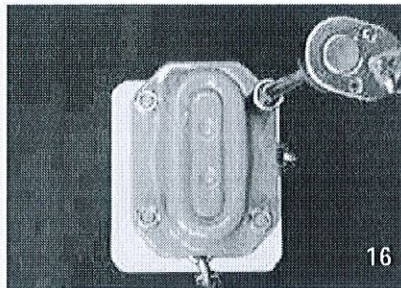

Tighten up with (p/107) Spring nuts.

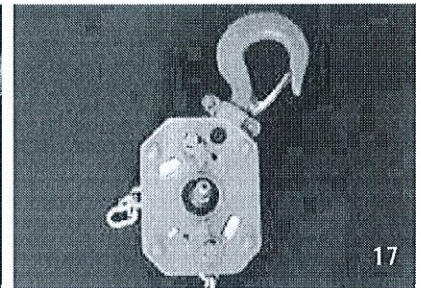

Reverse now-assembled unit, and fit (p/48) Top hook assembly with (p/51) Yoke pin.

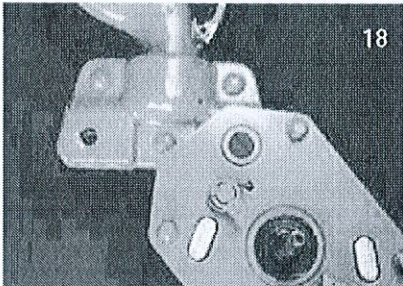

Be aware of the proper direction of the top hook assembly for 6.3t capacity.

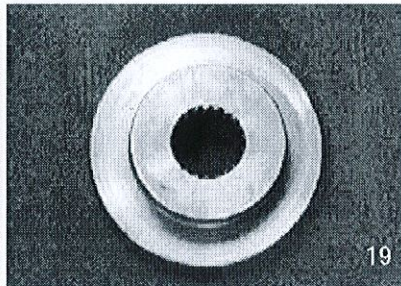

Be sure to keep (p/8) Disc hub away from any grease/oil material.

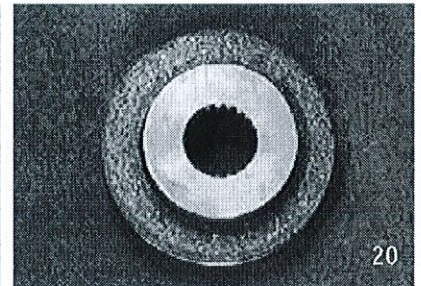

Fit (p/105) Brake lining. (Keep any grease/oil away.)

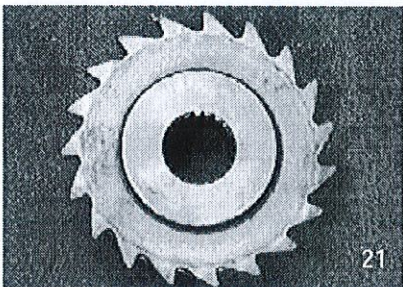

Grease slightly on the sliding surface of inner hole of (p/9) Ratchet wheel, then to mount it. (Be sure of the ratchet direction.)

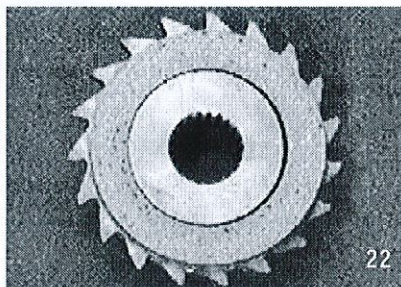

Mount (p/105) Brake lining. (Keep any grease/oil away from the brake unit other than process 21.)

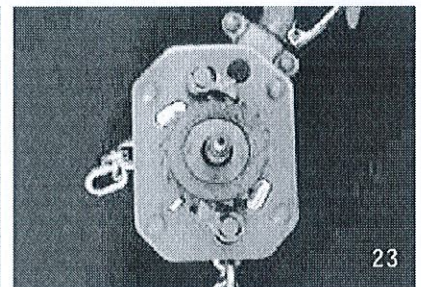

Attach complete brake assembly [(p/8) Disc hub, (p/105) Brake linings & (p/9) Ratchet wheel] on the main body. Then set the tip of each Pawl on the ratchet teeth.)

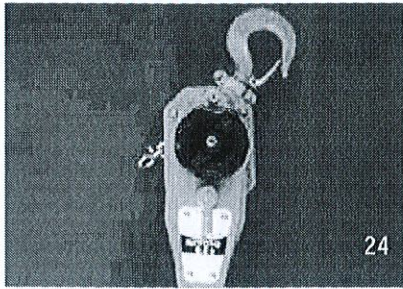

Connect Operating handle.

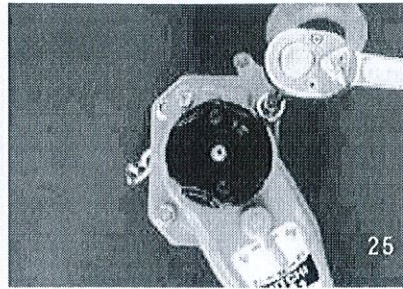

Tighten up with (p/107) Spring nuts.

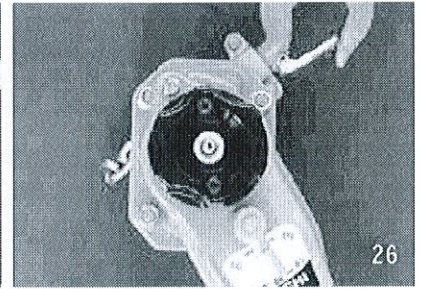

Fit (p/119) Plain washer.

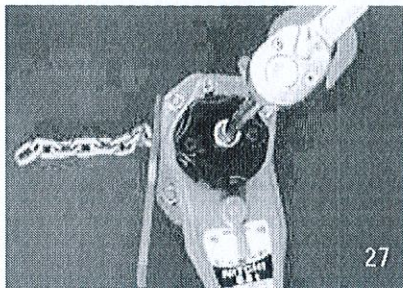

Turn Selector device to the Free-wheeling ( N ) position and tighten up with (p/120) Nylon nut. At this procedure, be sure to hold the load chain with a jig, and fasten Nylon nut securely.

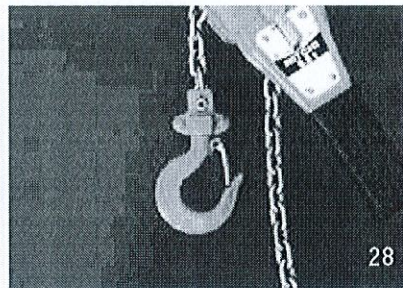

Connect (p/53) Bottom hook assembly with (p/124) Chain fastening bolt to (p/6) Load chain.

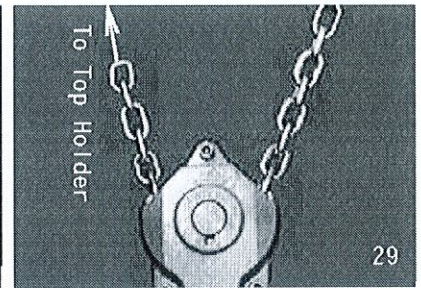

6.3t Capacity:  
Put Load chain through (p/53) Bottom hook assembly.  
(Always be sure the Load chain is free from twist or kink.)

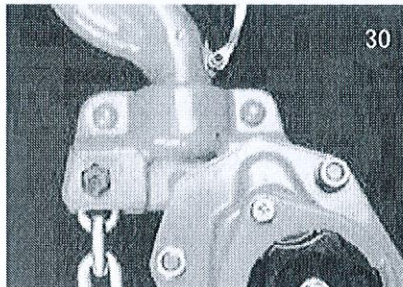

Connect Load chain reeved thru (p/53) Bottom hook assembly to (p/48) Top hook assembly with (p/124) Chain fastening bolt. (Always be sure the load chain is free from twist or kink.)

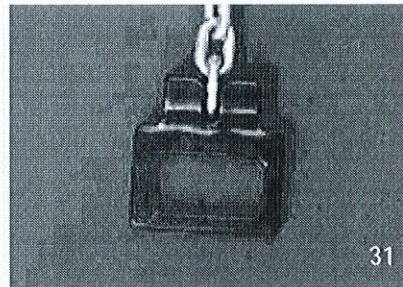

Fix (p/16) Stop grip assembly.

### 5 - 3. Assembly procedures of Operating handle(0.8~6.3t)

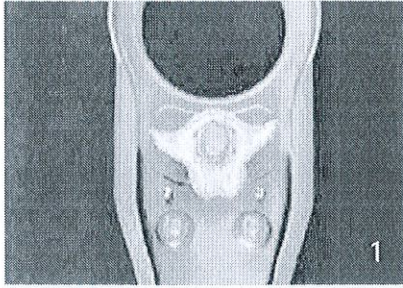

With Selector device being set at free-wheeling ( N ) position, install (p/32) Handle pawl to (p/24) Operating handle. Be sure its side of a marking comes to the reverse side.

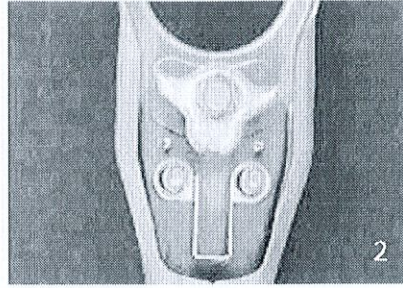

Seat (p/31) Shaft base.

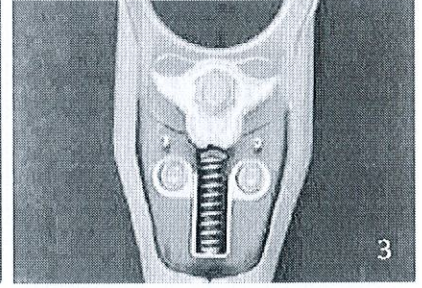

Attach (p/101) Change-over spring and (p/30) Spring shaft.

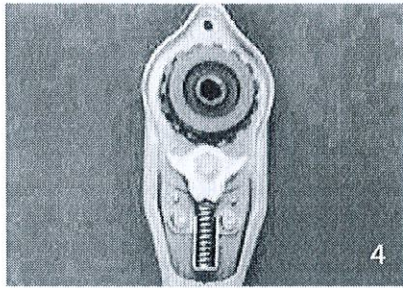

Place (p/23) Disc nut.

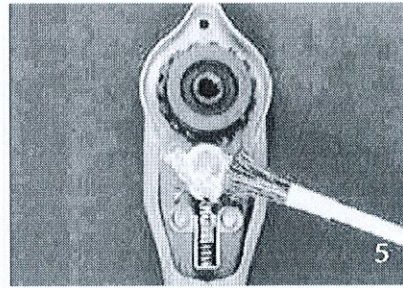

Grease to the shaft section of (p/32) Handle pawl and at its Spring shaft-contacting point. [CAUTION] Never grease to the tip of jaws of Handle pawl.

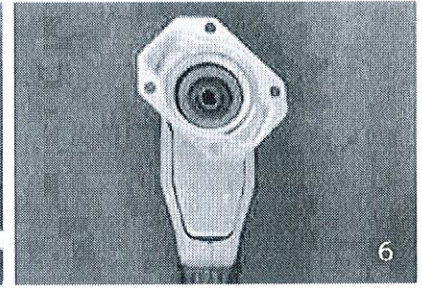

Mount (p/40) Ratchet cover assembly.

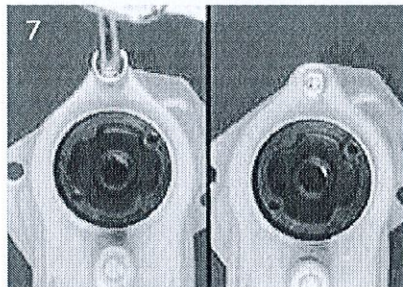

Reverse the handle unit and tighten up with (p/113) Upset head bolt.

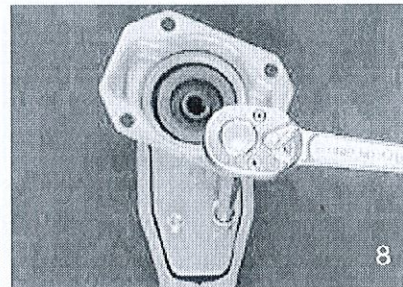

Reverse it again and tighten up with (p/111) Spring nuts.

#### 5 - 4. Assembly procedures of Bottom hook assembly(6.3t)

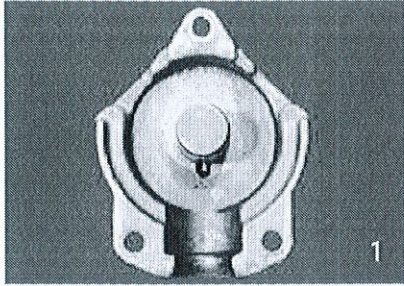

Attach (p/143) Knock pin on (p/56) Wheel pin, then put it on (p/53-3) Tail holder.

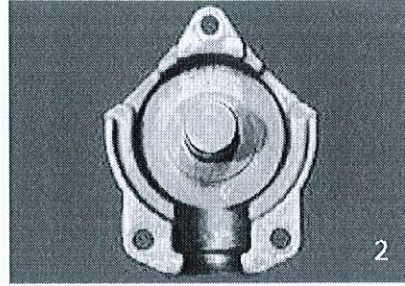

Insert (p/58) Collar for idle sheave.

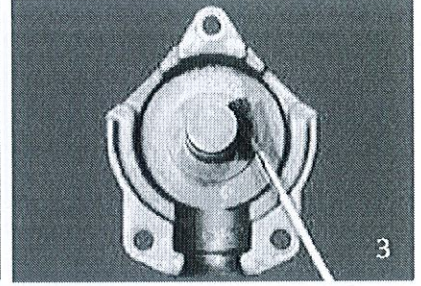

Grease to (p/56) Wheel pin.

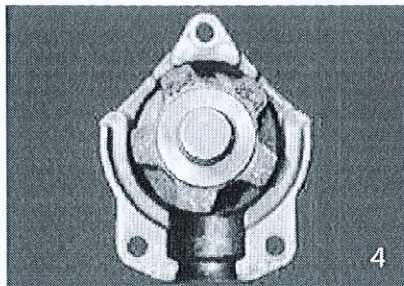

Install (p/55) Idle sheave.

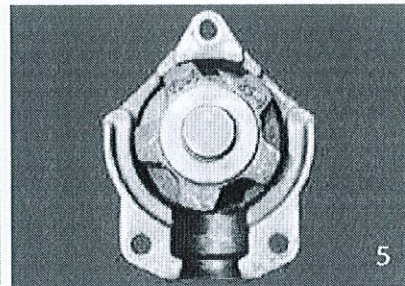

Then insert another (p/58) Collar for Idle sheave.

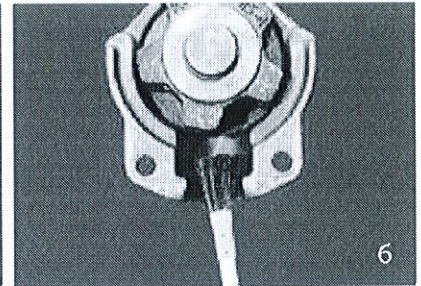

Grease to the point where the Hook is to be seated.

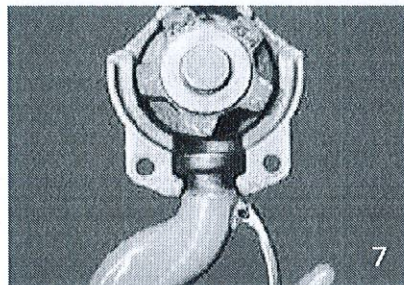

Fit Bottom hook.

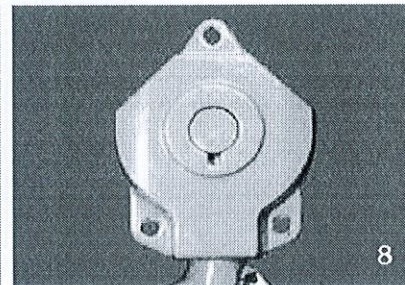

Attach Tail holder.

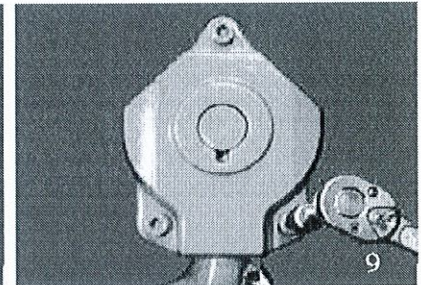

Tighten up with (p/141) Hex. socket head cap screws and (p/142) Spring nuts.

## 6. PARTS LIST

Exploded view (0.5t)

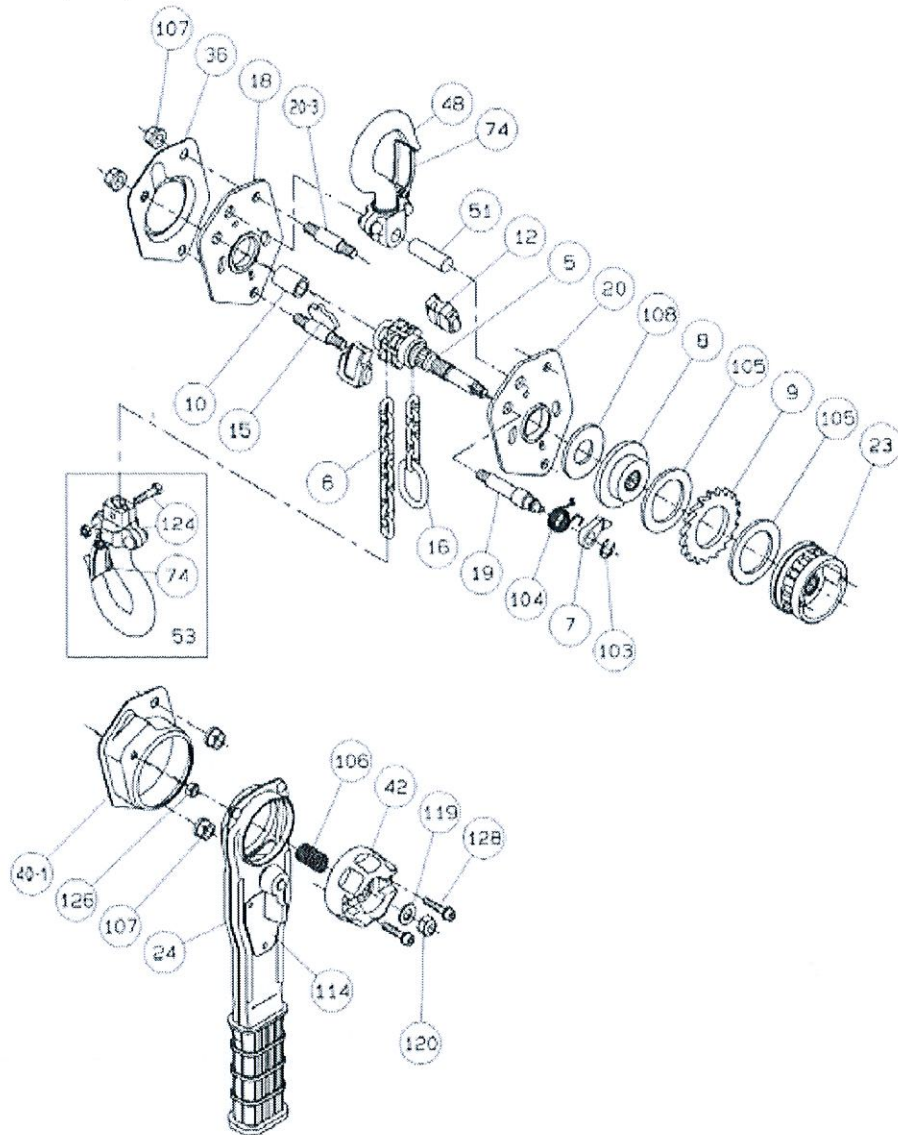

Index No.	Part Name	Nos. of used	0.5t	Index No.	Part Name	Nos. of used	0.5t
5	Load sheave	1	GRB5005	42	Guide handle	1	GRB5042
※6	Load chain	1	T-4XP	48	Top hook assembly	1	GRB5048U
7	Pawl	1	IRB5007	51	Yoke pin	1	GRB5051
8	Disc hub	1	IRB5008	53	Bottom hook assembly	1	GRB5053U
9	Ratchet wheel	1	IRB5009	74	Safety latch assembly	2	GRB5074T
10	Stay pipe	1	GRB5010	103	Retaining ring-E type	1	SRE8
12	Chain guide	2	GRB5012	104	Pawl spring	1	IRB5104
15	Stripper	1	GRB5015	105	Brake lining	2	IRB5105
16	Stop grip	1	DRP1021	106	Free-wheeling spring	1	NRB5106
18	Plain-side plate assembly	1	GRB5018T	107	Spring nut	5	HSN1M8
19	Stay bolt for pawl	1	GRB5019	108	Coned disc spring	1	GRB5108
20	Handle-side plate assembly	1	GRB5020T	114	Name plate	1	GRB5114
20-3	Stay bolt	2	GRB50203	119	Plain washer	1	PWM8M
23	Disc nut	1	GRB5023	120	Nylon nut	1	HNN1M8
24	Operating handle	1	GRB5024U	124	Chain fastening bolt	1	GRB4124T
36	Body cover	1	GRB5036	126	Lock nut	1	HUN1M6L
40-1	Ratchet cover	1	GRB50401	128	Hex.socket head cap screw	2	CBM5×25B3

Exploded view(0. 8t~6. 3t)

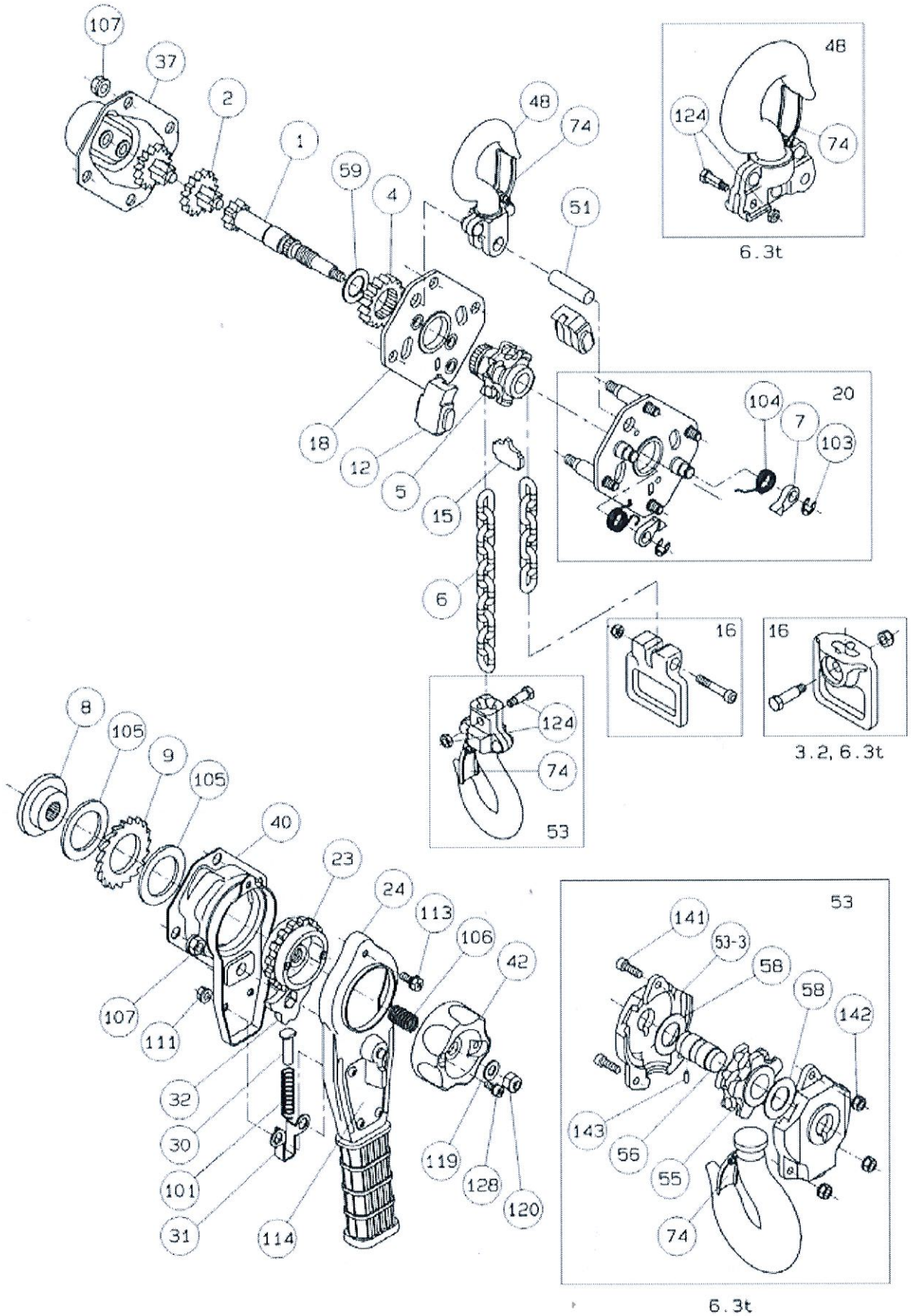

Index No.	Part name	Nos. of used	0. 8 t	1 t	1. 6 t	3. 2 t	6. 3 t	
1	Pinion shaft	1	IRB5001		KRB5001	NRB5001		
2	Pinion with pinion gear	2	IRB4002T		KRB4002T	NRB5002T		
4	Load gear	1	IRB4004	JRB4004	KRB5004	NRB5004		
5	Load sheave	1	IRB5005		KRB5005	NRB5005		
※6	Load chain	1	T-5.6XP		V-7.1XP	V-9XP		
7	Pawl	2	IRB5007		KRB5007			
8	Disc hub	1	IRB5008		KRB5008			
9	Ratchet wheel	1	IRB5009		KRB5009			
12	Chain guide	2	IRB5012		KRB5012	NRB5012		
15	Stripper	1	IRB5015		KRB5015	NRB5015		
16	Stop grip assembly	1	IRB40062T		KRB40062T	NRB40062T		
18	Gear-side plate assembly	1	IRB5018T		KRB5018T	NRB5018T		
20	Handle-side plate assembly	1	IRB5020U		KRB5020U	NRB5020U		
23	Disc nut	1	IRB5023		KRB5023			
24	Operating handle	1	IRB5024T		KRB5024T			
30	Spring shaft	1	IRB4030		IRB3030			
31	Shaft base	1	IRB4031		IRB3031			
32	Handle pawl	1	GRB5032		KRB5032			
37	Gear cover	1	IRB5037		KRB5037	NRB5037		
40	Ratchet cover assembly	1	IRB5040		KRB5040	NRB5040		
42	Guide handle	1	IRB5042					
48	Top hook assembly	1	IRB5048U	JRB5048U	KRB5048U	NRB5048U	QRB5048U	
51	Yoke pin	1	IRB5051		KRB5051	NRB5051		
53	Bottom hook assembly	1	IRB5053U	JRB5053U	KRB5053U	NRB5053U	QRB5053U	
53-3	Tail holder	2	_____					QRB50533
55	Idle sheave	1	_____					QRB5055
56	Wheel pin	1	_____					QRB5056
58	Collar for idle sheave	2	_____					HH4100083
59	Pinion shaft washer	1	IRB5059			NRB5059		
74	Safety latch assembly	2	GRB5074T	JRB5074T	KRB5074T		QRB5074T	
101	Change-over spring	1	IRB4101		IRB3116			
103	Retaining ring-E type	2	SRE8		SRE9			
104	Pawl spring	2	IRB5104		KRB5104	NRB5104		
105	Brake lining	2	IRB5105		KRB5105			
106	Free-wheeling spring	1	IRB5106		KRB5106	NRB5106		
107	Spring nut	8	HSN1M8			HSN1M10		
111	Spring nut	2	HSN1M6		HSN1M8			
113	Upset head bolt	1	CUSM6 × 10S2		CUSM8 × 12S2			
114	Name plate	1	IRB5114	JRB5114	KRB5114	NRB5114	QRB5114	
119	Plain washer	1	PWM8M					
120	Nylon nut	1	HNN1M8					
124	Chain fastening bolt	1	IRB4124T		KHH5048T	NRB4124T		
128	Hex.socket head cap screw	2	CBM5 × 25B3					
141	Hex.socket head cap screw	3	_____					CBM10 × 35
142	Spring nut	3	_____					HSNM10
143	Knock pin	1	_____					NP6 × 10

## 7. F-OLP Unit (Overload protection device)

- Consult NITCHI appointed distributor for the adjustment of overload protection device.

### 7 - 1. Assembly procedures

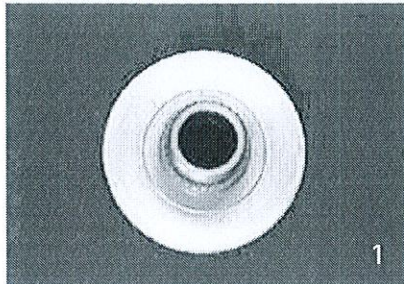

Keep (p/81) Disc nut for OLP away from any grease/oil.

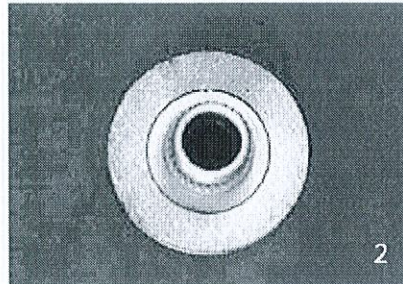

Insert a (p/118) Friction disc. (Keep this part free from any oil/grease.)

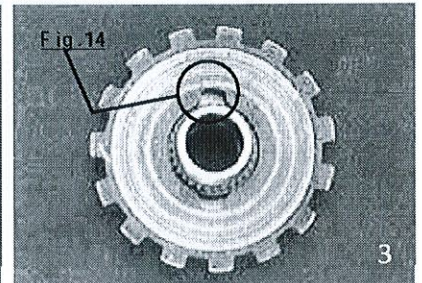

Attach (p/82) Friction gear. Apply solid lubricant to the sliding surface of its inner hole where the shank of (p/81) disc nut touches. [NOTE]

1. Never apply lubricant to the pockets for (p/117) Cylindrical rollers.
2. Be sure of the sides of this part. The pocket must appear as Fig.14 as its proper direction.

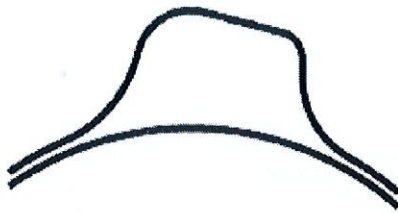
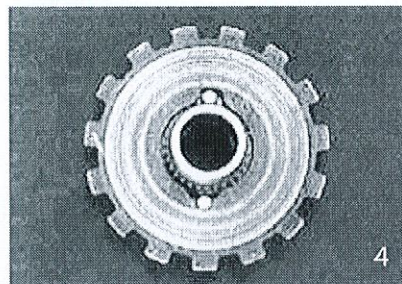
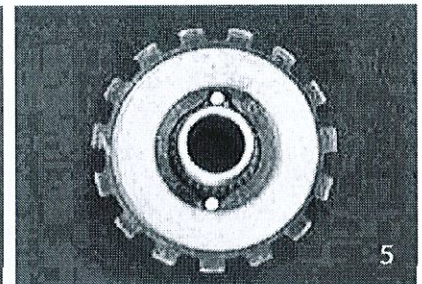

Fig.14 (p/82) Friction gear  
The pocket for (p/117) Cylindrical roller must appear like this.



Insert (p/117) Cylindrical rollers.



Insert another (p/118) Friction disc. (Keep this part free from any grease/oil.)

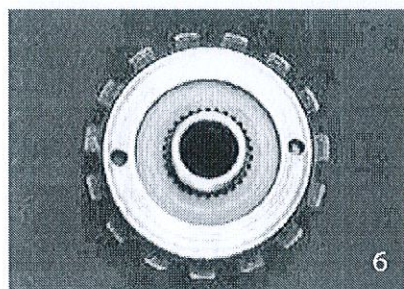

Attach (p/83) Friction hub. (Refer to Fig.15 for correct sides.)

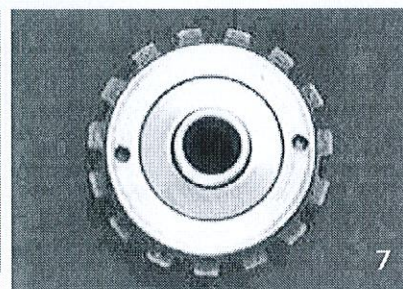

Mount (p/116) Coned disc spring. (Refer to Fig.15 for correct sides.)

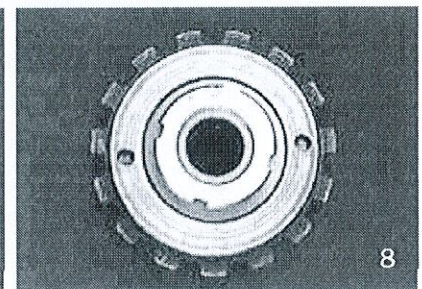

Tighten up with (p/110) Lock nut. (Refer to Fig.15 for correct sides.)

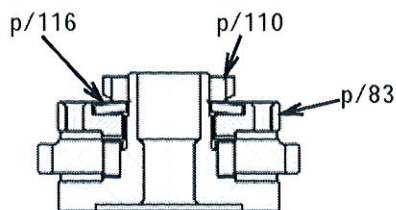
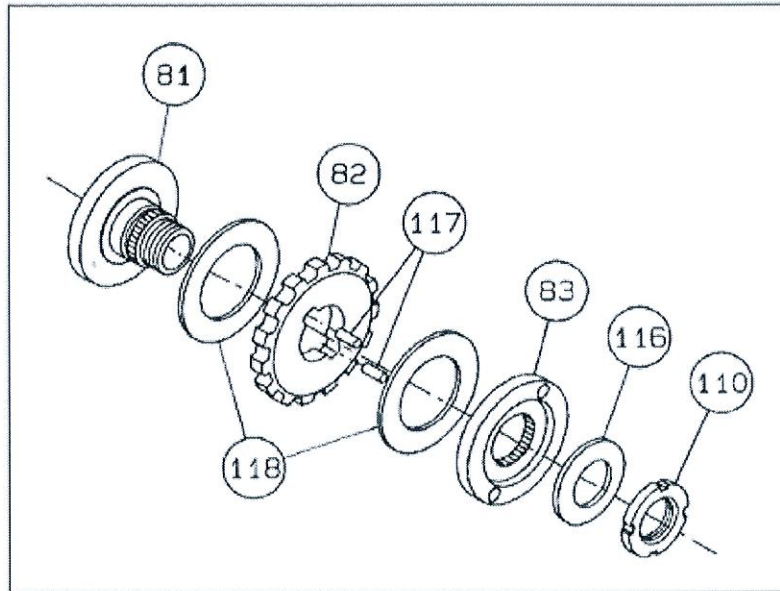

Fig.15 F-OLP unit

## 7 - 2. Parts list

Exploded view

(The standard model can be modified to the overload protection type by replacing its part No.23 Disc nut with the assembly part No.80 as under.)



P/N 80 Overload protection device

Index No.	Part name	Nos. of used	0. 5 t	0. 8 t	1 t	1. 6 t	3. 2 t	6. 3 t
80	Overload protection device	1	GRB5080U	IRB5080U	JRB5080U	KRB5080U	NRB5080U	QRB5080U
81	Disc nut for OLP	1	GRB5081	IRB5081			KRB5081	
82	Friction gear	1	GRB5082	IRB5082			KRB5082	
83	Friction hub	1	GRB5083			IRB5083		
110	Lock nut	1			GRB5110			
116	Coned disc spring	1			GRB5116			
117	Cylindrical roller	2	GRB5117			IRB5117		
118	Friction disc	2	GRB5118			IRB5118		



**HEAD OFFICE:**

2-2-1000, Umeda 1-Chome, Kita-Ku, Osaka city, Osaka, Japan 530-0001

TEL: +81-6-6344-6238 / FAX: +81-6-6456-2920

**FACTORY:**

7-17, Yoshida 4-Chome, Higashiosaka city, Osaka, Japan 578-0924

TEL: +81-729-61-2181 / FAX: +81-729-61-2188

**OVERSEAS SALES DEPARTMENT:**

104-18, Honjounishi 2-Chome, Higashiosaka city, Osaka, Japan 578-0965

TEL: +81-6-6748-6780 / FAX: +81-6-6748-6775

**Branches:**

Sapporo, Tokyo, Hokuriku, Nagoya, Osaka, Hiroshima, Kyushu.

The contents of this manual are subject to change without prior notice for corrections and improvements.